



SPLIT TYPE ROOM AIR  
CONDITIONER

WALL MOUNTED type

# SERVICE MANUAL

Models	Indoor unit	Outdoor unit
	RS-9LA	RO-9LA
	RS-12LA	RO-12LA



## C O N T E N T S

SPECIFICATIONS .....	1
DIMENSIONS .....	3
CIRCUIT DIAGRAM .....	4
REFRIGERANT SYSTEM DIAGRAM ....	5
ERROR CONTENTS .....	6
PCB CIRCUIT DIAGRAM .....	8
DISASSEMBLY ILLUSTRATION .....	10
PARTS LIST .....	13
STANDARD ACCESSORIES .....	15

# S P E C I F I C A T I O N S

TYPE	(COOL&HEAT INVERTER)	(COOL&HEAT INVERTER)
INDOOR UNIT	RS-9LA	RS-12LA
OUTDOOR UNIT	RO-9LA	RO-12LA
COOLING CAPACITY( ) : Range (kW)	2.6(0.5~3.6)	3.5(0.9~4.2)
HEATING CAPACITY( ) : Range (kW)	3.6(0.5~6.0)	4.8(0.9~6.6)

## ELECTRICAL DATA

POWER SOURCE (V)	230		
FREQUENCY (Hz)	50		
RUNNING CURRENT (A)	COOLING	3.0	4.6
	HEATING	3.6	5.8
INPUT WATTS (kW)	COOLING	0.68(0.25~1.38)	1.03(0.25~1.61)
	HEATING	0.91(0.25~1.96)	1.33(0.25~2.30)
EER (kW/kW)	COOLING	3.82	3.40
	HEATING	3.96	3.61
MOISTURE REMOVAL (r /hr)	1.3	1.8	
AIR CIRCULATION-Hi (m³/hr)	C 630 H665	C 630 H700	

## COMPRESSOR

TYPE	Hermetic type, 4 pole, 3 phase , DC brushles motor	
CODE	80206680	80206680
REFRIGERANT R410A (g)	950	1100

Note : Always use a vacuum pump to purge the air.  
Refrigerant for purging the air is not charged in the outdoor unit at the factory.

## FAN MOTOR

POWER SOURCE (V)	230	230	
INDOOR UNIT	HI-SPEED (r.p.m.)	C 1,350 H1,420	C 1,400 H1,470
	MED-SPEED (r.p.m.)	C 1,150 H1,200	C 1,200, H1,290
	LO-SPEED (r.p.m.)	C 950 H1,000	C 1,000 H1,110
	QUIET (r.p.m.)	C 740 H900	C 820 H980
OUTDOOR UNIT (r.p.m.)	830	830	

## DIMENSIONS

INDOOR UNIT	H x W x D (mm)	280 x 790x 230
OUTDOOR UNIT		535 x 780 x 250

## WEIGHTS

INDOOR UNIT	GROSS / NET (kg)	12 / 9	
OUTDOOR UNIT		35 / 33	37 / 34

## NOISE LEVEL

INDOOR UNIT	HI-SPEED (dB)	C 42 H 42	C 43 H 43
	MED-SPEED (dB)	C 37 H 36	C 39 H 38
	LO-SPEED (dB)	C 31 H 30	C 32 H 33
	QUIET (dB)	C 23 H 26	C 26 H 29
OUTDOOR UNIT (dB)		C 47 H 49	C 47 H 49

Note : Noise was measured in accordance with JIS standards, Japan.

PIPE LENGTH	7.5 m	10 m	15 m
ADDITIONAL REFRIGERANT	None	None	None

# DIMENSIONS

Models : RS-9LA / RO-9LA  
RS-12LA / RO-12LA

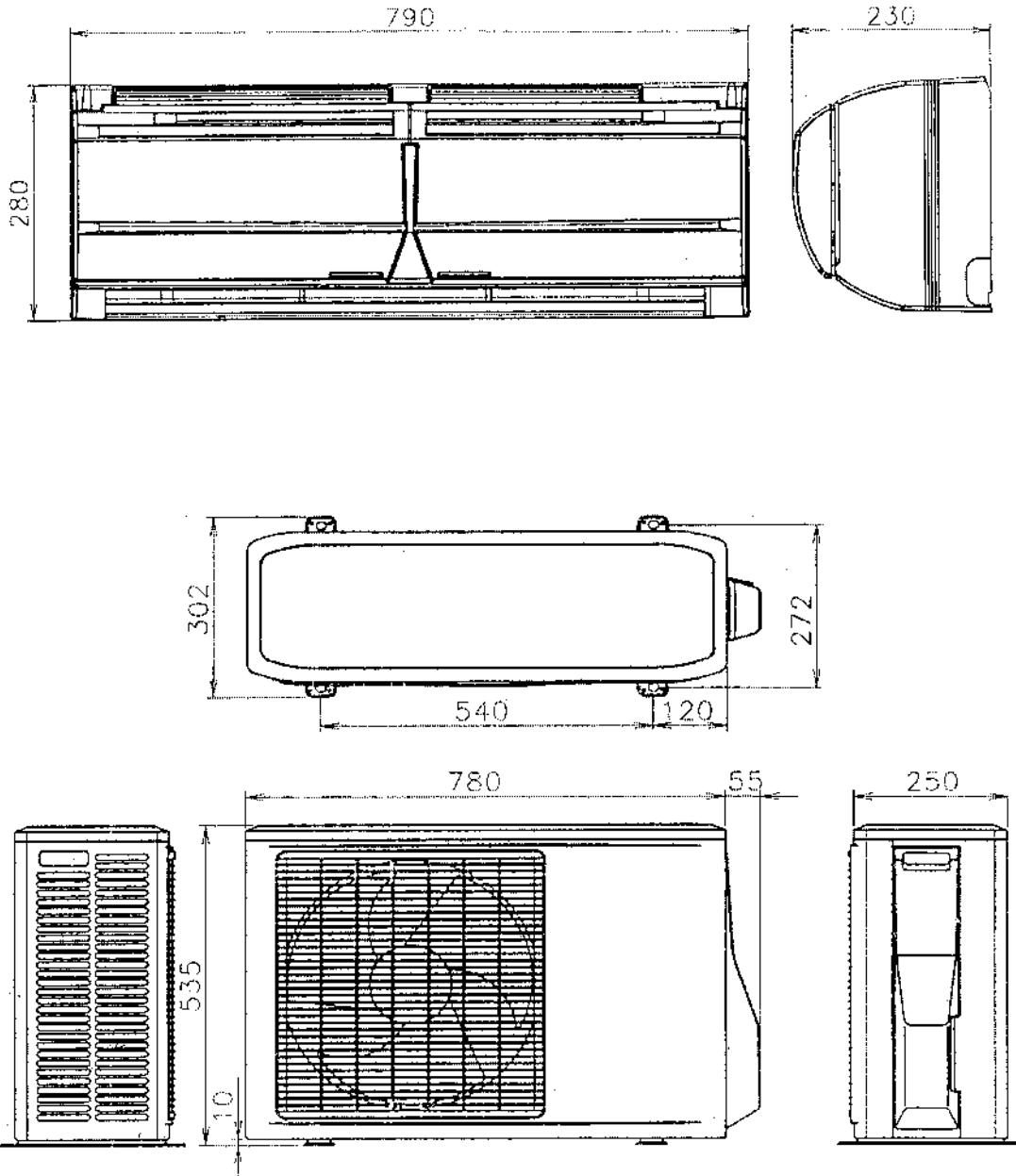

# CIRCUIT DIAGRAM

Models : RS-9LA / RO-9LA  
RS-12LA / RO-12LA

## INDOOR UNIT

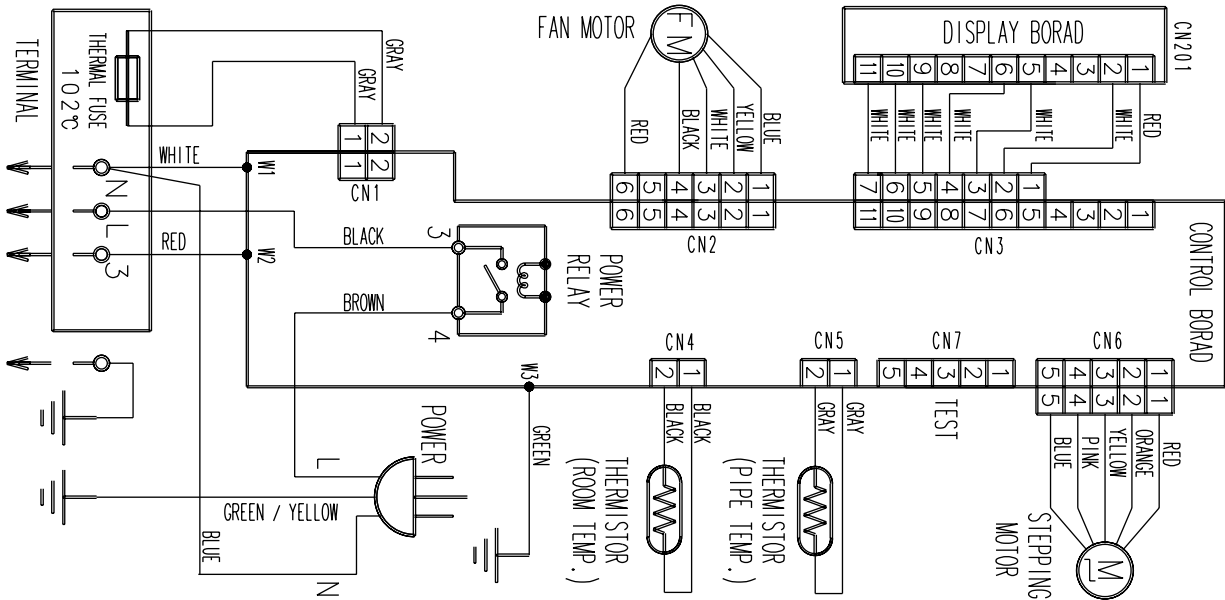

## OUTDOOR UNIT

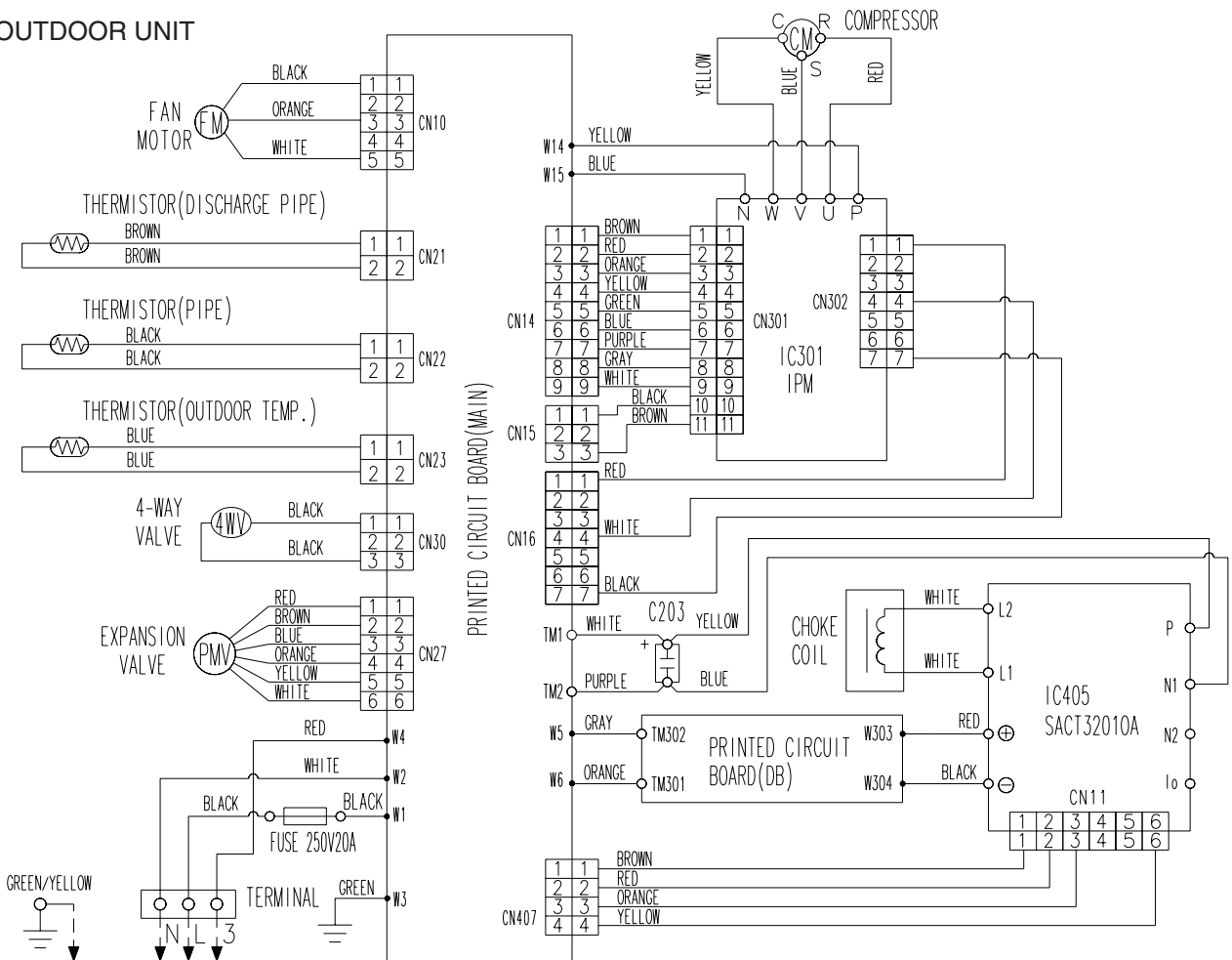

# REFRIGERANT SYSTEM DIAGRAM

Models : RS-9LA / RO-9LA  
RS-12LA / RO-12LA

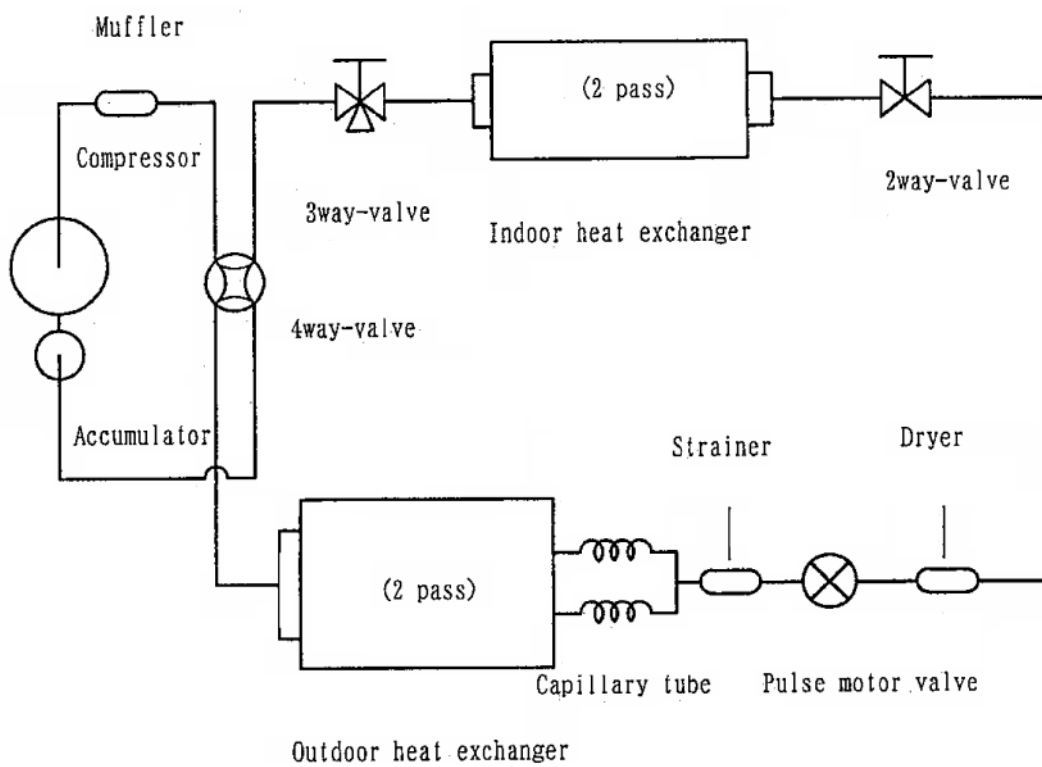

# ERROR CONTENTS

## Self-diagnosis function table (Flashing LED Display)

Applicable model : RS-9LA, RS-12LA

\* Detailed Trouble Display (secondary level) can be indicated by pressing Test Operation button.

Trouble Display (primary)			Detailed Trouble Display (by Test Button)			Detailed Error Item
Error	Operation	Timer	Error	Operation	Timer	
Serial Signal Error	Normal	1 sec blinking	Serial reverse signal error at operation start up	0.1sec blinking	0.5sec 2 times	Normal Serial Reverse Signal can not be received more than 10 seconds >>Releases when it becomes normal
			Signal reverse signal error during operation	0.1sec blinking	0.5sec 3 times	Normal Serial Reverse Signal can not be received more than 7 sec (after receiving effective reverse transfer signal) >>Releases when it becomes normal
			Serial forward signal error at operation start up	0.1sec blinking	0.5 sec 4 times	Normal Serial Forward Signal can not be received more than 10 sec >>Releases when it becomes normal
			Serial forward signal error during operation	0.1sec blinking	0.5sec 5 times	Normal Serial Forward Signal can not be received more than 10 sec ( after receiving effective forward transfer signal) >>Releases when it becomes normal
Indoor unit Thermister error	0.5sec 2 times	0.1sec blinking	Indoor Temperature Thermister Open	0.1sec blinking	0.5sec 2 times	Indoor Thermister detection value is open when AC plug is inserted >>Releases when value becomes normal
			Pipe Thermister Open or Short	0.1sec blinking	0.5sec 3 times	Indoor Thermister detection value is open or short when AC plug is inserted >>Releases when value becomes normal
Outdoor unit Thermister error	0.5sec 3 times	0.1sec blinking	Discharge Thermister Open or Short	0.1sec blinking	0.5sec 2 times	Outdoor Thermistor detection value is open or short >>Outdoor unit stops Releases when it becomes normal
			Heat Exchanger Thermister Open	0.1sec blinking	0.5sec 3 times	Outdoor Thermistor detection value is open >>Outdoor unit stops Releases when it becomes normal
			Outdoor Temperature Thermistor Open or Short	0.1sec blinking	0.5sec 4 times	Outdoor Thermistor detection value is open or short >>Outdoor unit stops Releases when it becomes normal
Indoor unit control error	0.5sec 4 times	0.1sec blinking	Forced Automatic SW welded	0.1sec blinking	0.5sec 2 times	Indoor Forced Auto SW is ON for more than 10 seconds continuously >>Error is indicated while it is ON Normal Operation other than error indition
			Main Relay welded	0.1sec blinking	0.5sec 3 times	Indoor Serial Reverse Signal is received 1 min. after Main relay becomes OFF >>Error is indicated while serial reverse signal is input on normal operation Normal operation except error indication
			Power interruption error	0.1sec blinking	0.5sec 4 times	Indoor 50/60Hz is not detected after 2 seconds of power ON. >>Error is indicated and unit is stopped

Trouble Display (primary)			Detailed Trouble Display (by Test Button)			Detailed Error Item	
Error	Operation	Timer	Error	Operation	Timer		
Outdoor unit control error	0.5sec 5 times	0.1sec blinking	Current Trip	0.1sec blinking	0.5sec 2 times	Outdoor	Current trip error is 2nd time within start up >>Permanent stop
			CT Abnormal	0.1sec blinking	0.5sec 3 times	Outdoor	Current detection value is 0A for more than 1 second when compressor is operated at more than 90rps >>Outdoor unit is stopped until power supply to Outdoor unit is stopped
			Compressor Rotation error	0.1sec blinking	0.5sec 5 times	Outdoor	Compressor location detection error (incl. failed start up) for 3 times >>Permanent stop
Indoor fan motor error	0.5sec 6 times	0.1sec blinking	Abnormal lock	0.1sec blinking	0.5sec 2 times	Indoor	Detected rotation is 0 rpm at start up or at 56 seconds after Fan mode is selected >>Permanent stop
			Abnormal rotation	0.1sec blinking	0.5sec 3 times	Indoor	Detected rotation is 1/3 of target r.p.m. at start up or at 56 seconds after Fan mode is selected >>Permanent stop
Refrigerant cycle error	0.5sec 7 times	0.1sec blinking	Discharge Temperature abnormal	0.1sec blinking	0.5sec 2 times	Outdoor	Discharge Temperature protection (Discharge temperature is 110degC) operated 2 times >>Permanent stop
			Cooling High Pressure abnormal rise	0.1sec blinking	0.5sec 3 times	Outdoor	High pressure rise protection (Outdoor heat exchanger temperature is 65degC) operated >>Comp. OFF (releases after 3min.ST) Error is indicated while 3 min.ST
Optional function Error	0.5sec 8 times	0.1sec blinking	Active Filter Voltage abnormal (3rd time)	0.1sec blinking	0.5sec 2 times	Outdoor	Active Filter voltage error operated 3 times >>Permanent stop
			Active Filter Voltage abnormal (1st time)	0.1sec blinking	0.5sec 3 times	Outdoor	Active Filter Module error or open detection protection operated >>Automatic release after 3 min. ST



# OUTDOOR PRINTED CIRCUIT BOARD CIRCUIT DIAGRAM

CONTROLLER PCB ASSEMBLY ( MAIN PCB)  
 AOY9LSAC : EZ-002LHUE-C  
 AOY12LSAC : EZ-002GHUE-C

POWER SOURCE  
 220 - 240V  
 50Hz

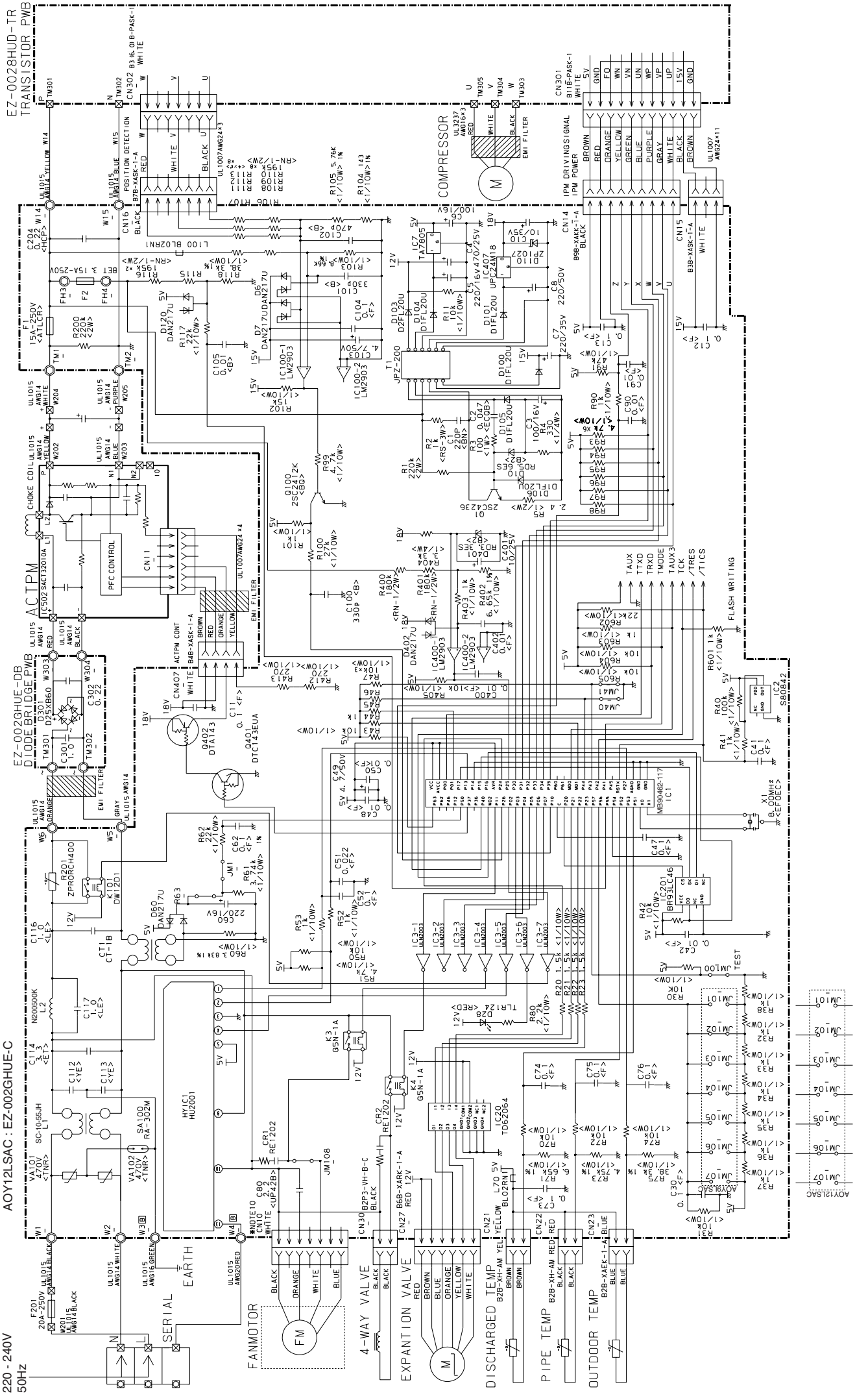

# DISASSEMBLY ILLUSTRATION

Models :  
RS-9LA  
RS-12LA

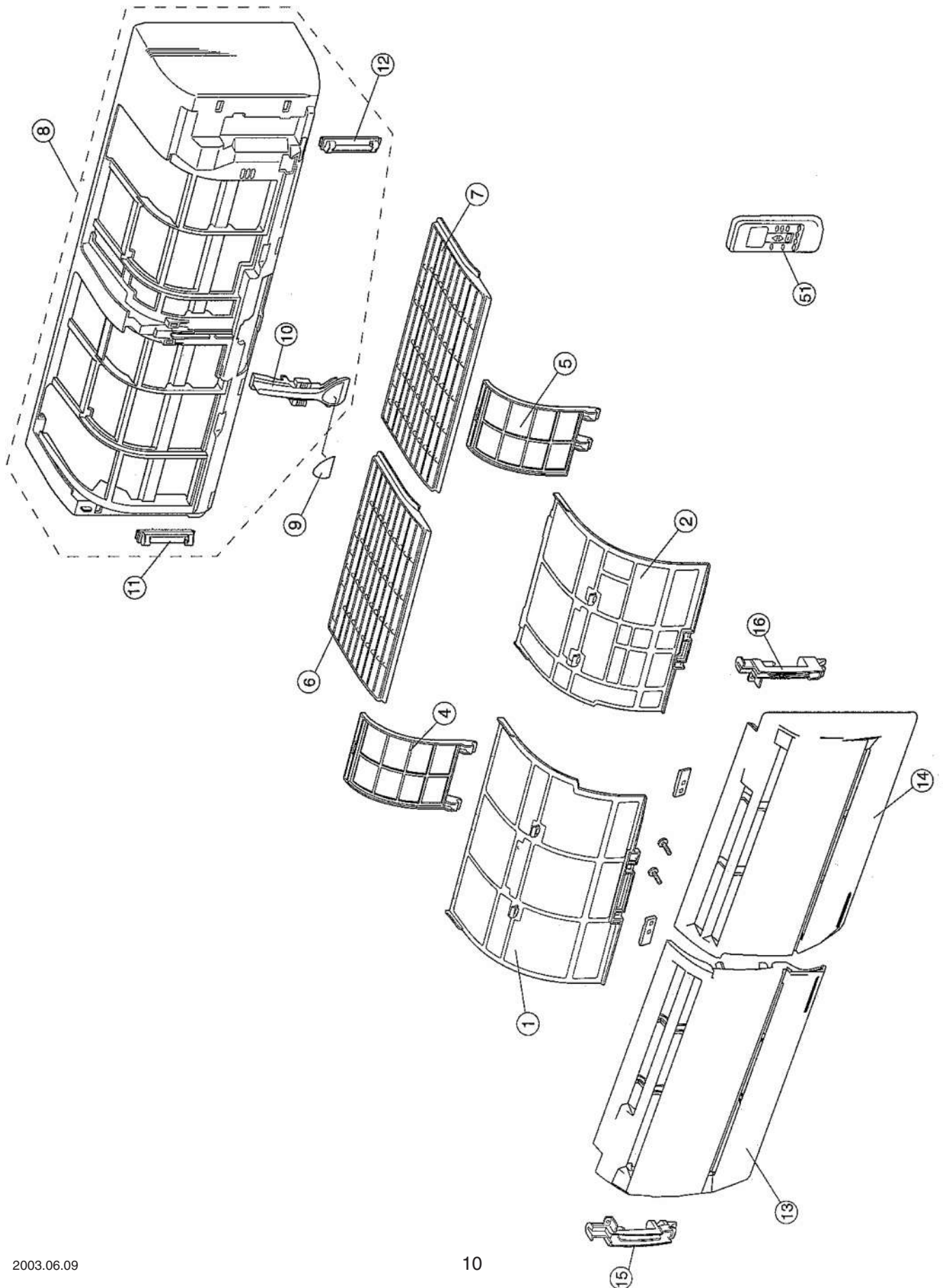

Models :  
RS-9LA  
RS-12LA

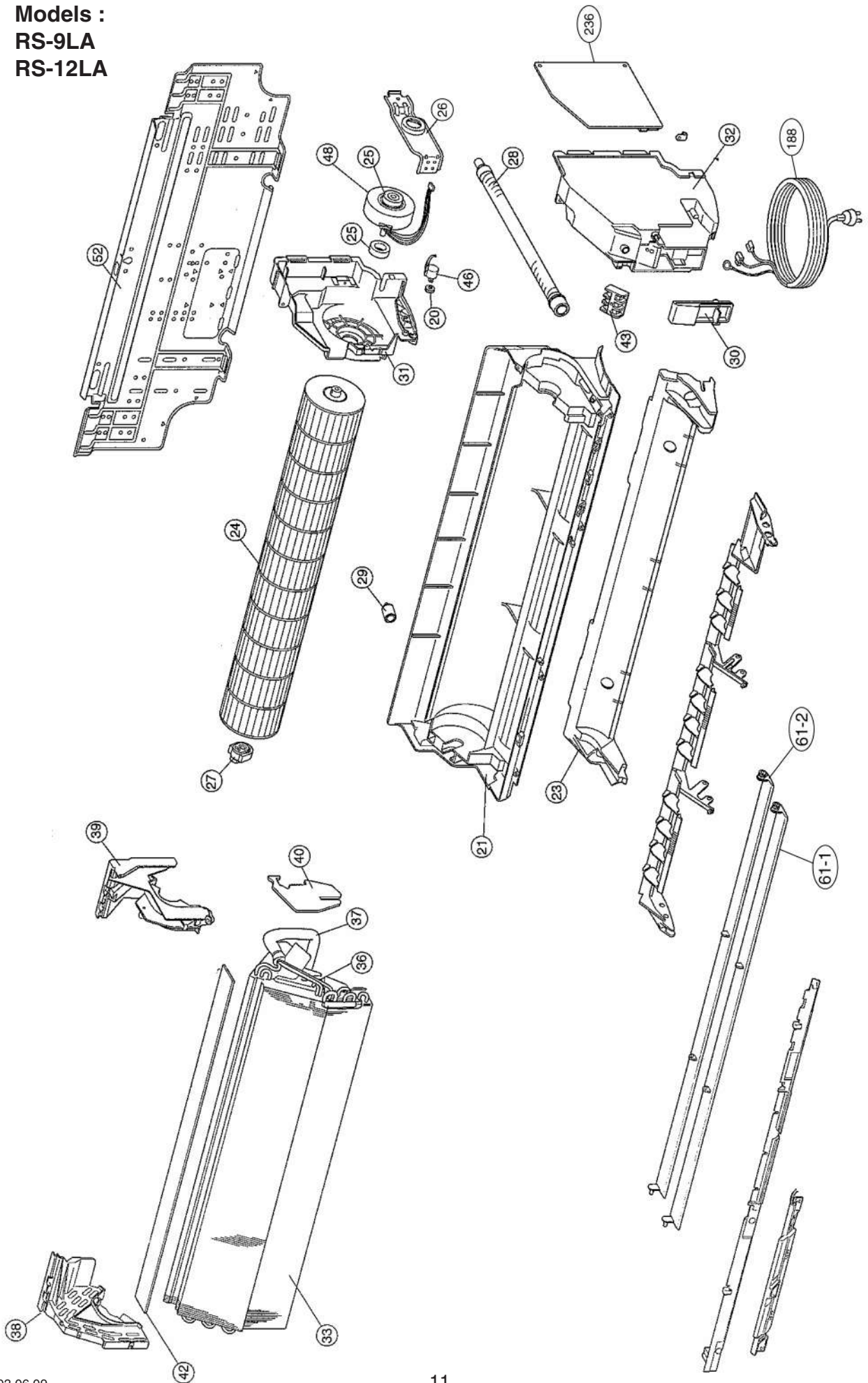

Models :  
RO-9LA  
RO-12LA

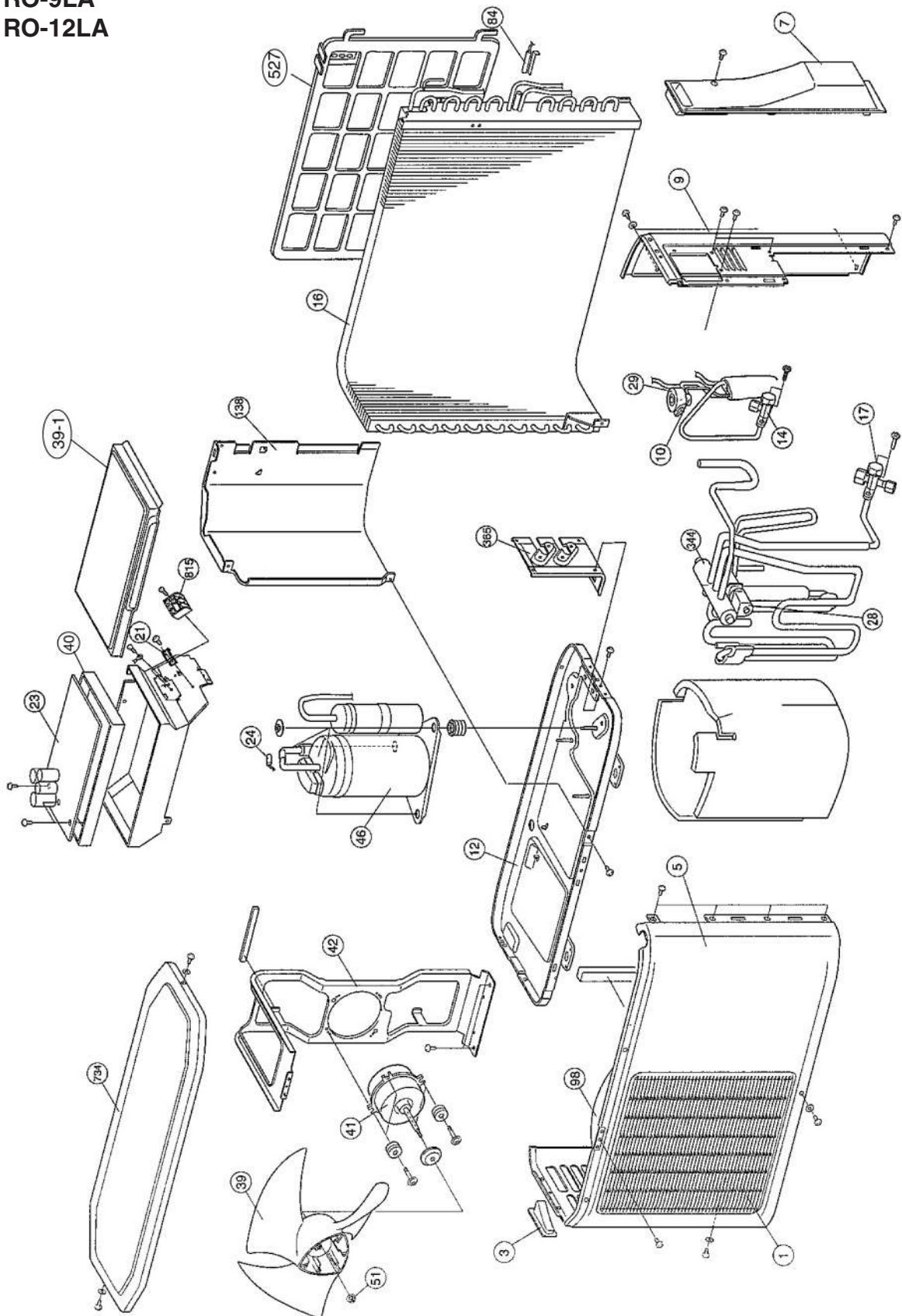

## PARTS LIST

When you order parts, please make a photocopy of this page and fill the number of the parts in the "Order" column.

### INDOOR UNIT

Ref. No.	Description	Part No.		Ord. Q'ty	Ref. No.	Description	Part No.		Ord. Q'ty
		RS-9LA	RS-12LA				RS-9LA	RS-12LA	
1	Air Filter-L	9311027010	9311027010		28	Drain Hose Assy	9310357019	9310357019	
2	Air Filter-R	9311028017	9311028017		29	Drain Cap Assy	9304150008	9304150008	
4	Guide (Filter)-L	9311180012	9311180012		30	Wire Clamper	9311946014	9311946014	
5	Guide (Filter)-R	9311254010	9311254010		31	Box (Switch)	9309996014	9309996014	
6	Grill (Top)-L	9311025023	9311025023		32	Cover (Switch)	9311863014	9311863014	
7	Grill (Top)-R	9311026020	9311026020		33	Evaporator Total Assy	9311495017	9311495017	
8	Front Panel Assy	9311903048	9311903048		36	Joint Pipe Assy-E	9311497011	9311497011	
9	Emblem-A	9311784050	9311784050		37	Insulation (Pipe)-E	9304607007	9304607007	
10	Emblem-B	9311785026	9311785026		38	Holder (Evaporator)-L	9309982017	9309982017	
11	Bearing (Panel)-L	9311029014	9311029014		39	Holder (Evaporator)-R	9309983014	9309983014	
12	Bearing (Panel)-R	9311030010	9311030010		40	Water Seal	9310721001	9310721001	
13	Grill (Intake)-L	9311782049	9311782049		42	Air Seal	9310611005	9310611005	
14	Grill (Intake)-R	9311783039	9311783039		43	Terminal	9701955077	9701955077	
15	Shaft (Grill)-L	9311031017	9311031017		46	Step Motor	9900139025	9900139025	
16	Shaft (Grill)-R	9311149019	9311149019		48	Fan Motor Assy	9601351016	9601351016	
20	Gear-A	9309994003	9309994003		51	Remote Control Unit	9312058013	9312058013	
21	Casing Assy	9312112036	9312112036		52	Bracket Panel	9310001004	9310001004	
23	Cover (Casing)-B	9311916017	9311916017		61-1	Flow Control Panel-U	9309991026	9309991026	
24	Cross Flow Fan Assy	9307836015	9307836015		61-2	Flow Control Panel-Z	9309992023	9309992023	
25	Motor Cushion-B	9306274009	9306274009		188	Power Cord	9702595067	9900157012	
26	Clamper (Motor)	9310102008	9310102008		236	Controller PCB Assy	9705001053	9705001060	
27	Shaft Holder-C Assy	9306628017	9306628017						

When you order parts, please make a photocopy of this page and fill the number of the parts in the "Order" column.

**OUTDOOR UNIT**

Ref. No.	Description	Part No.		Ord. Q'ty	Ref. No.	Description	Part No.		Ord. Q'ty
		RO-9LA	RO-12LA				RO-9LA	RO-12LA	
1	Blow Grill	9309929012	9309929012		29	Coil (Expansion Valve)	9900057015	9900057015	
3	Grip	9302061016	9302061016		39	Propeller Fan	9309909014	9309909014	
5	Cabinet Front Panel, Painted	9309928053	9309928053		39-1	Inverter Cover	9311017011	9311017011	
7	Electric Cover	9310979013	9310979013		40	Inverter Base	9311015017	9311015017	
9	Cabinet Rear Panel, Painted	9309870024	9309870024		41	Fan Motor Assy	9601474012	9601474012	
10	Pulse Motor Valve	9900056018	9900056018		42	Bracket (Motor)	9306047023	9306047030	
12	Base Assy, Painted	9310248027	9310248027		46	Compressor Assy	9312448012	9312448012	
14	2-Way Valve Assy	9310084014	9310084014		84	Thermistor (Condenser)	9704220011	9704220011	
16	Condenser Sub Assy	9312586028	9312586011		98	Fan Ring	9309876026	9309876026	
17	3-Way Valve Assy	9311487012	9311487012		138	Separate Wall	9311013013	9311013013	
23	Inverter PCB Assy	9705092020	9705092013		344	4-Way Valve	9900047016	9900047016	
24	Thermistor (Discharge)	9704219060	9704219060		527	Protective Net	9310980019	9310980019	
28	Solenoid Coil	9970033018	9970033018		734	Panel Top, Painted	9310338063	9310338063	