

AIR CONDITIONER

Cassette type

SERVICE MANUAL

INDOOR

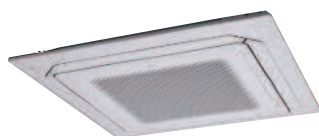

AUXG24KRLB
AUXG30KRLB
AUXG36KRLB
AUXG45KRLB
AUXG54KRLB

OUTDOOR



AOYG24KATA



AOYG30KATA
AOYG36KATA



AOYG45KATA
AOYG54KATA

FUJITSU GENERAL LIMITED

Notices:

- Product specifications and design are subject to change without notice for future improvement.
- For further details, please check with our authorized dealer.

Trademarks

FGLair™ is trademark of Fujitsu General Limited in the United States, other countries or both.

Google Play™ is trademark of Google LLC.

App Store® is a service mark of Apple Inc., registered in the U.S. and other countries.

CONTENTS

1. GENERAL INFORMATION

2. TECHNICAL DATA AND PARTS LIST

1. GENERAL INFORMATION

CONTENTS

1. GENERAL INFORMATION

1. Specifications	01-1
1-1. Indoor unit	01-1
1-2. Outdoor unit.....	01-5
2. Dimensions	01-8
2-1. Indoor unit	01-8
2-2. Outdoor unit.....	01-12

1. Specifications

1-1. Indoor unit

Type				Cassette			
				Inverter heat pump			
Model name				AUXG24KRLB	AUXG30KRLB	AUXG36KRLB	
Power supply				230 V ~ 50 Hz			
Power supply intake				Outdoor unit			
Available voltage range				198—264 V			
Capacity	Cooling	Rated	kW	6.8	8.5	9.5	
			Btu/h	23,200	29,000	32,400	
		Min.—Max.	kW	0.9—7.4	2.8—9.6	2.8—10.6	
	Heating	Rated	Btu/h	3,100—25,200	9,600—32,700	9,600—36,100	
			kW	7.5	10.0	10.8	
		Min.—Max.	kW	0.9—8.6	2.7—10.8	2.7—12.5	
				Btu/h	3,100—29,300	9,200—36,800	9,200—42,600
Input power	Cooling	Rated	kW	2.12	2.56	3.06	
				Max.	2.60	3.53	4.19
	Heating	Rated	1.97	2.64	2.58		
			Max.	2.58	4.17	4.48	
Current	Cooling	Rated	A	9.3	11.3	13.6	
	Heating			8.7	11.7	11.4	
Power factor	Cooling			98.6	98.2	98.0	
	Heating			98.9	98.2	98.0	
EER	Cooling			3.21	3.32	3.10	
COP	Heating			3.81	3.79	4.19	
Moisture removal			L/h (pints/h)	2.7 (4.8)	2.5 (4.4)	3.3 (5.8)	
Maximum operating current *1	Cooling			12.6	22.5		
	Heating			12.6	22.5		
Fan	Airflow rate	Cooling	m ³ /h	HIGH	1,150	1,600	1,870
				MED	1,050	1,400	1,560
				LOW	980	1,270	1,410
				QUIET	870	1,150	1,160
		Heating	HIGH	1,150	1,600	1,870	
			MED	1,050	1,400	1,560	
			LOW	980	1,270	1,410	
			QUIET	870	1,150	1,160	
	Type × Qty			Turbo fan × 1			
	Motor output			W	81		
Sound pressure level *2	Cooling	dB (A)	HIGH	35	40	44	
			MED	33	38	41	
			LOW	32	36	38	
			QUIET	29	33	34	
	Heating	HIGH	35	40	44		
		MED	33	38	41		
		LOW	32	36	38		
		QUIET	29	33	34		
Heat exchanger type	Dimensions (H × W × D)		mm	Main1: 210 × 2,127 × 13.3 Main2: 210 × 2,061 × 13.3	Main1: 252 × 2,127 × 13.3 Main2: 252 × 2,061 × 13.3	Main1: 252 × 2,131 × 13.3 Main2: 252 × 2,064 × 13.3 Main3: 252 × 1,999 × 13.3	
	Fin pitch			Main1: 1.2 Main2: 1.2		Main1: 1.3 Main2: 1.3 Main3: 1.3	
	Rows × Stages		Main1: 1 × 10 Main2: 1 × 10		Main1: 1 × 12 Main2: 1 × 12	Main1: 1 × 12 Main2: 1 × 12 Main3: 1 × 12	
	Pipe type		Copper tube				
	Fin type		Aluminum				
Dimensions (H × W × D)	Net		mm	246 × 840 × 840	288 × 840 × 840		
	Gross			298 × 960 × 950	340 × 960 × 950		
Weight	Net		kg	24	26	29	
	Gross			29	32	34	
Connection pipe	Size	Liquid	mm (in)	Ø 6.35 (Ø 1/4)	Ø 9.52 (Ø 3/8)		
		Gas		Ø 12.70 (Ø 1/2)	Ø 15.88 (Ø 5/8)		
Method		Flare					
Material		PVC					
Drain hose		Size		Ø 25 (I.D.), Ø 32 (O.D.)			
Operation range	Cooling	°C	18 to 32				
		%RH	80 or less				
Heating	°C	16 to 30					
Cassette grille (Option)	Model name			UTG-UKYC-W			
	Material			Polyvinyl chloride			
	Color			White			
				Approximate color of Munsell N 9.25/			
	Dimensions (H × W × D)	Net	mm	53 × 950 × 950			
		Gross		110 × 1,000 × 1,010			
Weight	Net	kg	6.0				
	Gross		10.0				
Remote control (Option)				Wired remote controller, Wireless remote controller, Mobile app*3 (FGLair™)			

Type	Cassette		
	Inverter heat pump		
Model name	AUXG24KRLB	AUXG30KRLB	AUXG36KRLB
<p>NOTES:</p> <ul style="list-style-type: none"> • Specifications are based on the following conditions: <ul style="list-style-type: none"> – Cooling: Indoor temperature of 27 °CDB/19 °CWB, and outdoor temperature of 35 °CDB/24 °CWB. – Heating: Indoor temperature of 20 °CDB/15 °CWB, and outdoor temperature of 7 °CDB/6 °CWB. – Pipe length: 5.0 m, Height difference: 0 m. (Between outdoor unit and indoor unit.) • Protective function might work when using it outside the operation range. • *1: Maximum operating current is the total current of the indoor unit and the outdoor unit. • *2: Sound pressure level: <ul style="list-style-type: none"> – Measured values in manufacturer's anechoic chamber. – Because of the surrounding sound environment, the sound levels measured in actual installation conditions might be higher than the specified values here. • *3: Available on Google Play™ store or on App Store®. Optional WLAN Adapter is also required. For details, refer to the setting manual. • This data is based on EN 14511 standard. 			

Specifications for ErP Lot10					
Model name		AUXG24KRLB		AUXG30KRLB	AUXG36KRLB
Energy efficiency class	Cooling	A++			
	Heating (Average)	A+			
Pdesign	Cooling	kW	6.8 (35°C)	8.5 (35°C)	9.5 (35°C)
	Heating (Average)		5.4 (-10°C)	8.0 (-10°C)	8.7 (-10°C)
SEER	Cooling	kWh/kWh	6.10		
SCOP	Heating (Average)		4.00		
Annual energy consumption	QCE	kWh/a	390	488	545
	QHE (Average)		1,887	2,794	3,044
Sound power level	Cooling	HIGH	dB (A)	49	54
	Heating			49	54

Type				Cassette						
				Inverter heat pump						
Model name				AUXG45KRLB	AUXG54KRLB					
Power supply				230 V ~ 50 Hz						
Power supply intake				Outdoor unit						
Available voltage range				198—264 V						
Capacity	Cooling	Rated	kW	12.1	13.4					
		Min.—Max.	Btu/h	41,300	45,700					
			kW	4.00—12.60	4.50—13.80					
	Heating	Min.—Max.	Btu/h	13,600—43,000	15,400—47,100					
			kW	13.5	13.7					
		Rated	Btu/h	46,000	46,700					
Input power	Cooling	Rated	kW	4.32	4.87					
				Max.	5.00	5.23				
		Heating		Rated	3.77	4.29				
	Max.		4.69		4.77					
	Current		Cooling	Rated	A	18.8	21.4			
		Heating				16.6	18.8			
Power factor				99.7	99.0					
EER				2.80	2.75					
COP				3.58	3.19					
Moisture removal				L/h (pints/h)	4.5 (7.9)	5.0 (8.8)				
Maximum operating current *1				Cooling	28.1					
				Heating	28.1					
Fan	Airflow rate	Cooling	m ³ /h	HIGH	2,000	2,100				
				MED	1,650	1,780				
				LOW	1,460	1,600				
				QUIET	1,300	1,320				
		Heating		HIGH	2,000	2,100				
				MED	1,650	1,780				
				LOW	1,460	1,600				
				QUIET	1,300	1,320				
	Type × Q'ty				Turbo fan × 1					
	Motor output				W		81			
Sound pressure level *2				Cooling	dB (A)	HIGH	46	47		
						MED	42	43		
						LOW	39	40		
						QUIET	35	36		
				Heating		HIGH	46	47		
						MED	42	43		
						LOW	39	40		
						QUIET	35	36		
Heat exchanger type				Dimensions (H × W × D)		Main1: 252 × 2,131 × 13.3 Main2: 252 × 2,064 × 13.3 Main3: 252 × 1,999 × 13.3				
				Fin pitch		Main1: 1.3 Main2: 1.3 Main3: 1.3				
				Rows × Stages		Main1: 1 × 12 Main2: 1 × 12 Main3: 1 × 12				
				Pipe type		Copper tube				
				Fin type		Aluminum				
				Dimensions (H × W × D)				Net		288 × 840 × 840
Gross				340 × 960 × 950						
Weight				Net		29				
				Gross		34				
Connection pipe				Size	Liquid Gas	mm (in)	Ø 9.52 (Ø 3/8)			
							Ø 15.88 (Ø 5/8)			
Method				Flare						
Material				Polyvinyl chloride						
Drain hose				Size		mm	Ø 25 (I.D.), Ø 32 (O.D.)			
Operation range				Cooling	°C	18 to 32				
						%RH	80 or less			
				Heating	°C	16 to 30				
Cassette grille (Option)				Model name		UTG-UKYC-W				
				Material		Polystyrene				
				Color		White Approximate color of Munsell N 9.25/				
				Dimensions (H × W × D)				Net		53 × 950 × 950
								Gross		110 × 1,000 × 1,010
				Weight				Net		6.0
Gross		10.0								
Remote control (Option)				Wired remote controller, Wireless remote controller, Mobile app*3 (FGLair™)						
NOTES:										
<ul style="list-style-type: none"> Specifications are based on the following conditions: <ul style="list-style-type: none"> Cooling: Indoor temperature of 27 °CDB/19 °CWB, and outdoor temperature of 35 °CDB/24 °CWB. Heating: Indoor temperature of 20 °CDB/15 °CWB, and outdoor temperature of 7 °CDB/6 °CWB. Pipe length: 5.0 m, Height difference: 0 m. (Between outdoor unit and indoor unit.) Protective function might work when using it outside the operation range. *1: Maximum operating current is the total current of the indoor unit and the outdoor unit. *2: Sound pressure level: <ul style="list-style-type: none"> Measured values in manufacturer's anechoic chamber. Because of the surrounding sound environment, the sound levels measured in actual installation conditions might be higher than the specified values here. *3: Available on Google Play™ store or on App Store®. Optional WLAN Adapter is also required. For details, refer to the setting manual. This data is based on EN 14511 standard. 										

1-2. Outdoor unit

Type				Inverter heat pump	
Model name				AOYG24KATA	
Power supply				230 V ~ 50 Hz	
Power supply intake				Outdoor unit	
Available voltage range				198–264 V	
Starting current			A	9.7	
Fan	Airflow rate	Cooling	m ³ /h	2,885	
		Heating		2,350	
	Type × Q'ty			Propeller × 1	
	Motor output		W	49	
Sound pressure level *1		Cooling	dB (A)	54	
		Heating		55	
Sound power level		Cooling	dB (A)	66	
		Heating		67	
Heat exchanger type		Dimensions (H × W × D)	mm	Main1: 588 × 881 × 18.19 Main2: 588 × 851 × 18.19	
		Fin pitch		Main1: 1.3 Main2: 1.3	
		Rows × Stages		Main1: 1 × 28 Main2: 1 × 28	
		Pipe type		Copper	
		Fin	Type (Material)	Aluminum	
			Surface treatment	PC fin	
Compressor	Type × Q'ty			DC Twin rotary × 1	
	Motor output		W	1,060	
Refrigerant		Type (Global warming potential)		R32 (675)	
		Factory charge	g	1,250	
Refrigerant oil		Type		RmM68AF	
		Amount	cm ³	400	
Enclosure		Material		Steel sheet	
		Color		Beige Approximate color of Munsell 10YR 7.5/1.0	
Dimensions (H × W × D)		Net		mm	
		Gross			632 × 799 × 290 692 × 940 × 375
Weight		Net		kg	
		Gross			38 42
Connection pipe		Size	Liquid	mm (in)	
			Gas		Ø 6.35 (Ø 1/4) Ø 12.70 (Ø 1/2)
		Method		Flare	
		Pre-charge length		m	20
		Max. length			25
		Max. height difference			20
Operation range		Cooling	°C	-10 to 46	
		Heating		-15 to 24	
Drain hose		Material		PP	
		Size		mm	Ø13.0 (I. D.), Ø16.0 to Ø16.8 (O. D.)

NOTES:

- Specifications are based on the following conditions:
 - Cooling: Indoor temperature of 27 °CDB/19 °CWB, and outdoor temperature of 35 °CDB/24 °CWB.
 - Heating: Indoor temperature of 20 °CDB/15 °CWB, and outdoor temperature of 7 °CDB/6 °CWB.
 - Pipe length: 5.0 m, Height difference: 0 m. (Between outdoor unit and indoor unit.)
- Protective function might work when using it outside the operation range.
- *1: Sound pressure level
 - Measured values in manufacturer's anechoic chamber.
 - Because of the surrounding sound environment, the sound levels measured in actual installation conditions might be higher than the specified values here.
- This data is based on EN 14511 standard.

Type			Inverter heat pump		
Model name			AOYG30KATA		AOYG36KATA
Power supply			230 V ~ 50 Hz		
Power supply intake			Outdoor unit		
Available voltage range			198–264 V		
Starting current			12.3	13.8	
Fan	Airflow rate	Cooling	m ³ /h	3,750	
		Heating		3,750	
	Type × Q'ty	Propeller × 1			
Motor output			W		
			100		
Sound pressure level *1	Cooling	Heating	dB (A)	53	55
				55	
Sound power level	Cooling	Heating	dB (A)	68	70
				70	
Heat exchanger type	Dimensions (H × W × D)		mm	Main1: 756 × 905 × 18.19 Main2: 756 × 905 × 18.19	
	Fin pitch			Main1: 1.45 Main2: 1.45	
	Rows × Stages		Main1: 1 × 36 Main2: 1 × 36		
	Pipe type		Copper		
	Fin	Type (Material)	Aluminum		
		Surface treatment	Blue fin		
Compressor	Type × Q'ty	DC Twin rotary × 1			
	Motor output	W			
			1,500		
Refrigerant	Type (Global warming potential)		R32 (675)		
	Factory charge		g		
			1,900		
Refrigerant oil	Type		FW68D		
	Amount		cm ³		
			600		
Enclosure	Material		Steel sheet		
	Color		Beige Approximate color of Munsell 10YR 7.5/1.0		
Dimensions (H × W × D)	Net		mm	788 × 940 × 320	
	Gross			966 × 1,027 × 445	
Weight	Net		kg	52	
	Gross			61	
Connection pipe	Size	Liquid	mm (in)	Ø 9.52 (Ø 3/8)	
		Gas		Ø 15.88 (Ø 5/8)	
	Method		Flare		
	Pre-charge length		30		
	Max. length		30		
	Max. height difference		30		
Operation range	Cooling	Heating	°C	-10 to 46	
				-15 to 24	
Drain hose	Material		LDPE		
	Size		mm		
			Ø 13.0 (I. D.), Ø 16.0 to Ø 16.7 (O. D.)		
NOTES:					
<ul style="list-style-type: none"> • Specifications are based on the following conditions: <ul style="list-style-type: none"> – Cooling: Indoor temperature of 27 °CDB/19 °CWB, and outdoor temperature of 35 °CDB/24 °CWB. – Heating: Indoor temperature of 20 °CDB/15 °CWB, and outdoor temperature of 7 °CDB/6 °CWB. – Pipe length: 5.0 m, Height difference: 0 m. (Between outdoor unit and indoor unit.) • Protective function might work when using it outside the operation range. • *1: Sound pressure level <ul style="list-style-type: none"> – Measured values in manufacturer's anechoic chamber. – Because of the surrounding sound environment, the sound levels measured in actual installation conditions might be higher than the specified values here. • This data is based on EN 14511 standard. 					

Type			Inverter heat pump		
Model name			AOYG45KATA		AOYG54KATA
Power supply			230 V ~ 50 Hz		
Power supply intake			Outdoor unit		
Available voltage range			198—264 V		
Starting current			21.3		21.4
Fan	Airflow rate	Cooling	m ³ /h	4,450	
		Heating		4,780	
	Type × Q'ty	Propeller × 1			
Motor output			W 120		
Sound pressure level *1	Cooling		dB (A)	58	
	Heating			61	
Sound power level	Cooling		dB (A)	72	
	Heating			75	
Heat exchanger type	Dimensions (H × W × D)		mm	Main1: 966 × 905 × 18.19 Main2: 966 × 905 × 18.19	
	Fin pitch			Main1: 1.45 Main2: 1.45	
	Rows × Stages		Main1: 1 × 46 Main2: 1 × 46		
	Pipe type		Copper		
	Fin		Type (Material) Surface treatment	Aluminum Blue fin	
Compressor	Type × Q'ty		DC Twin rotary × 1		
	Motor output		1,830		2,180
Refrigerant	Type (Global warming potential)		R32 (675)		
	Factory charge		g 2,400		
Refrigerant oil	Type		RmM68AF		
	Amount		cm ³ 800		
Enclosure	Material		Steel sheet		
	Color		Beige Approximate color of Munsell 10YR 7.5/1.0		
Dimensions (H × W × D)	Net		mm	998 × 940 × 320	
	Gross			1,176 × 1,027 × 445	
Weight	Net		kg	61	
	Gross			71	
Connection pipe	Size	Liquid	mm (in)	Ø 9.52 (Ø 3/8)	
		Gas		Ø 15.88 (Ø 5/8)	
	Method		Flare		
	Pre-charge length		30		
	Max. length		m	30	
Max. height difference		30			
Operation range	Cooling		°C	-10 to 46	
	Heating			-15 to 24	
Drain hose	Material		LDPE		
	Size		mm Ø 13.0 (I. D.), Ø 16.0 to Ø 16.7 (O. D.)		

NOTES:

- Specifications are based on the following conditions:
 - Cooling: Indoor temperature of 27 °CDB/19 °CWB, and outdoor temperature of 35 °CDB/24 °CWB.
 - Heating: Indoor temperature of 20 °CDB/15 °CWB, and outdoor temperature of 7 °CDB/6 °CWB.
 - Pipe length: 5.0 m, Height difference: 0 m. (Between outdoor unit and indoor unit.)
- Protective function might work when using it outside the operation range.
- *1: Sound pressure level
 - Measured values in manufacturer's anechoic chamber.
 - Because of the surrounding sound environment, the sound levels measured in actual installation conditions might be higher than the specified values here.
- This data is based on EN 14511 standard.

2. Dimensions

2-1. Indoor unit

■ Model: AUXG24KRLB

Unit: mm

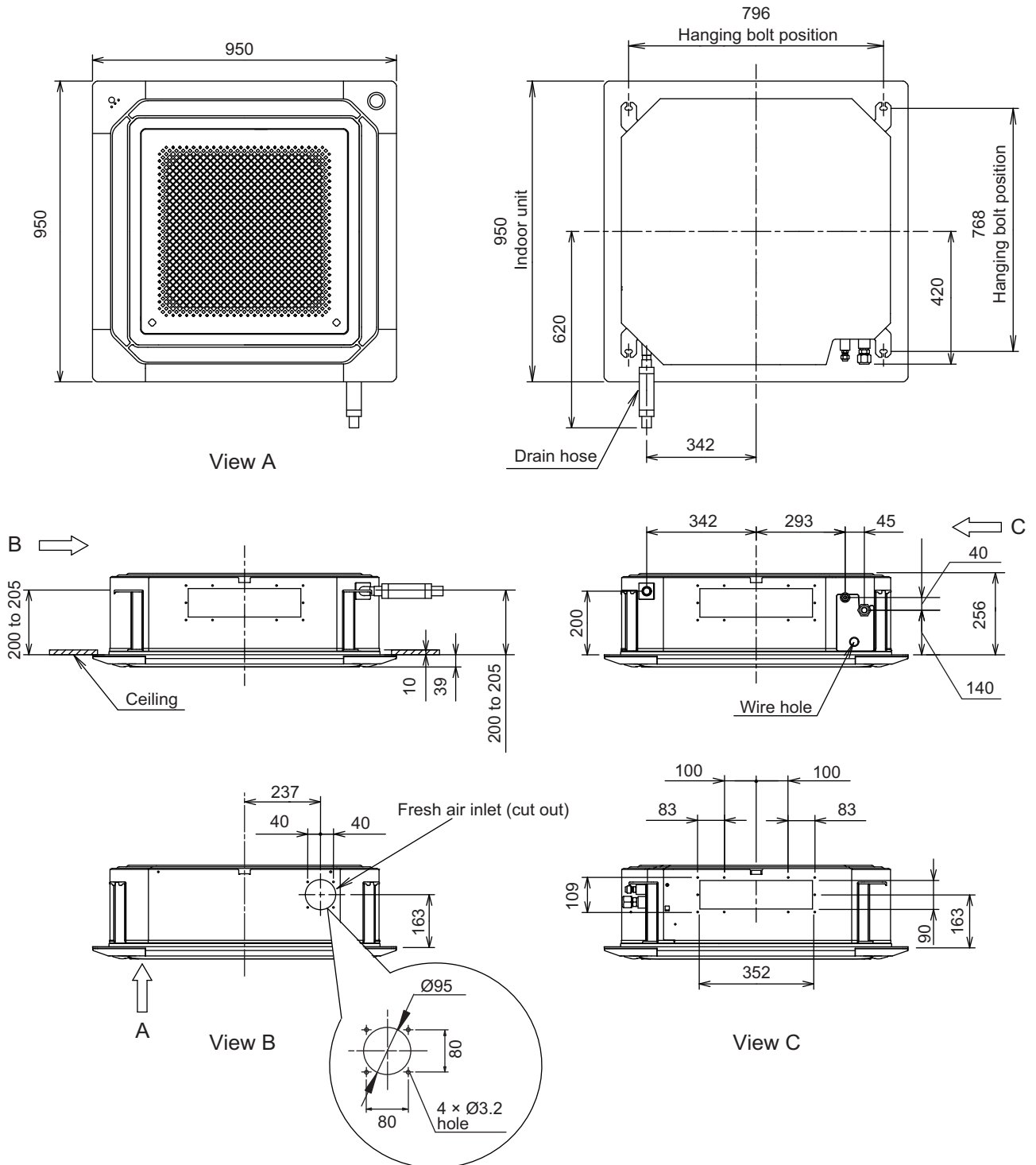

■ Models: AUXG30KRLB, AUXG36KRLB, AUXG45KRLB, and AUXG54KRLB

Unit: mm

GENERAL INFORMATION

GENERAL INFORMATION

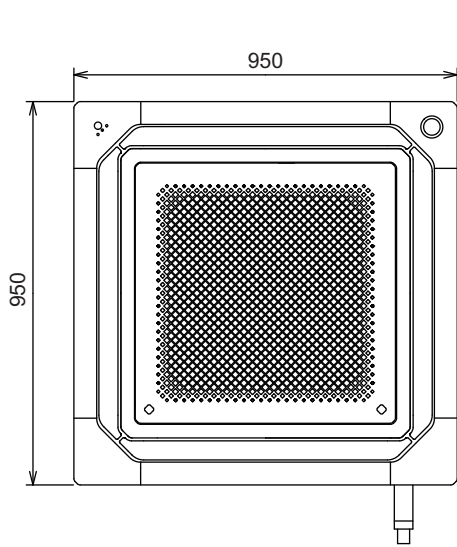

View A

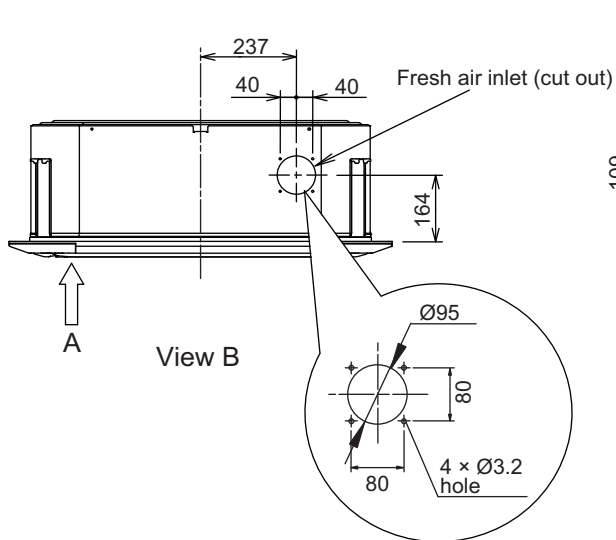
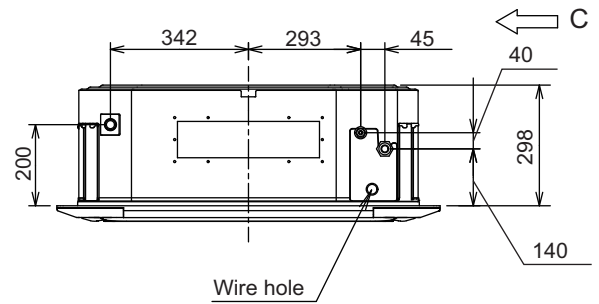
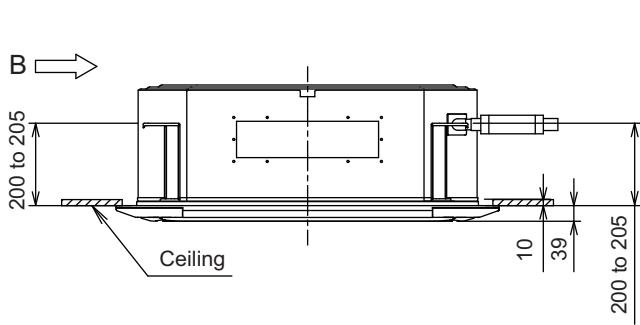
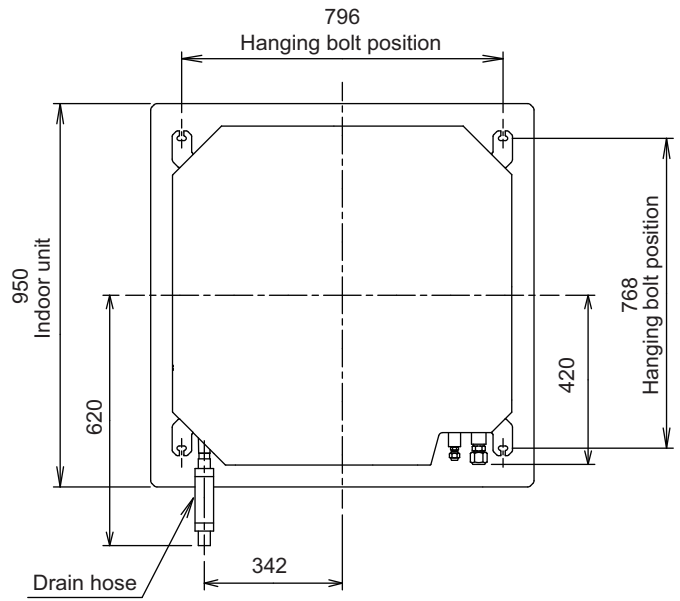

View B

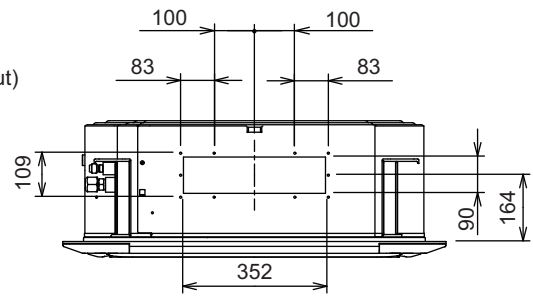

View C

■ Installation space requirement

Unit: mm

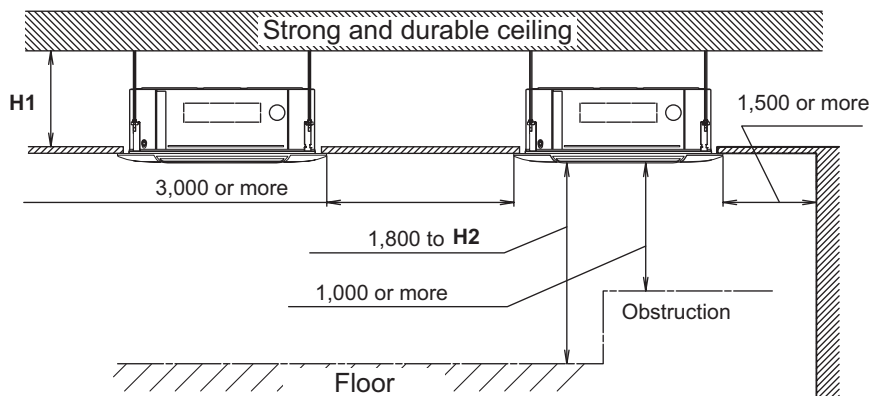

Model name	H1: Attic height
AUXG24KRLB	256 or more
AUXG30-54KRLB	298 or more

Be sure to make function setting with the remote controller according to the installed ceiling height.

H2: The maximum height from floor to ceiling		
Ceiling height	Model name	
	AUXG24KRLB	AUXG30-54KRLB
Standard	3,000	3,200
High ceiling	3,500	4,200

● Installation notices

- When installing the indoor unit, be careful about the maintenance space.
- To set "3-direction", Air Outlet Shutter Plate (option) must be installed, and the "outlet-direction" need to be switched to "3-way" by the remote controller.

Unit: mm

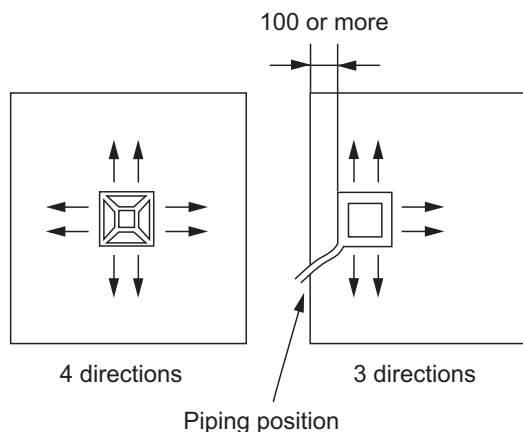

- In 3-way outlet mode, changing of ceiling height setting by function setting 20 is prohibited. (Ceiling height setting [function setting 20] is allowed to be changed only in 4-way outlet mode.)
- Use the Insulation Kit for High Humidity (option), when the condition under the roof is over 80% in humidity and over 30°C in temperature. Otherwise, there is a risk of condensation on the ceiling.

• Human sensor (Option)

NOTE: A separate device capable of controlling the human sensor (energy saving) function, such as the Touch Panel Controller, is required for use.

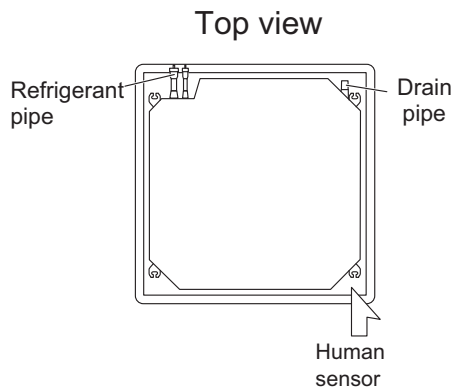

Example of sensitivity range:

Unit: mm

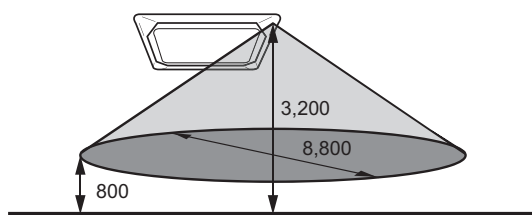

Equal sensitivity range of temperature	Ceiling height	3,200
	Detecting position	800 from floor surface

NOTE: When the installation height gets higher, the temperature sensitivity decreases.

⚠ CAUTION

- Do not place large objects near the human sensor.
- Keep any other heating units outside the sensor's detection area.

2-2. Outdoor unit

■ Model: AOYG24KATA

Unit: mm

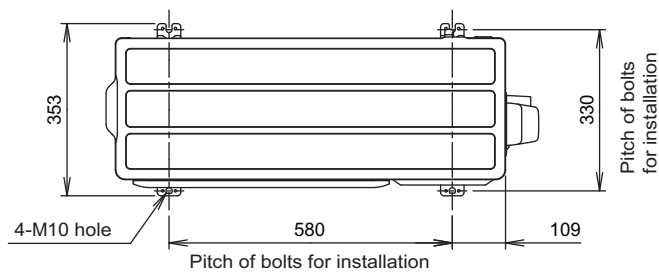

Top view

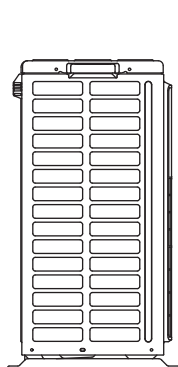

Side view

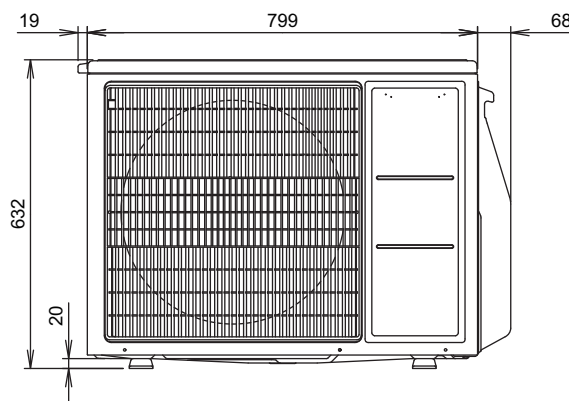

Front view

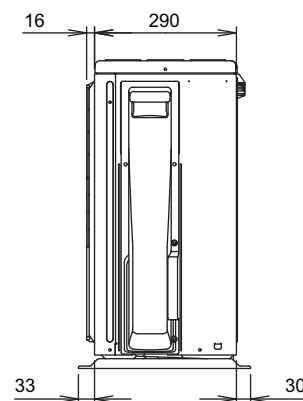

Side view

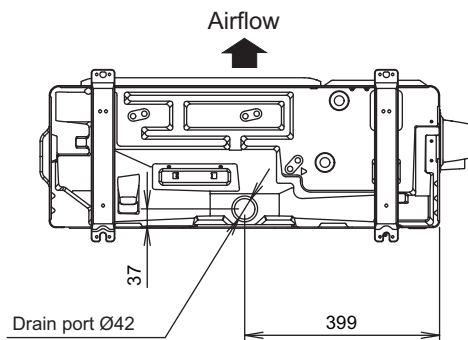

Bottom view

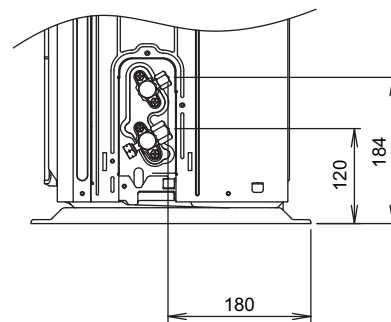

Side view (Valve part)

Models: AOYG30KATA and AOYG36KATA

Unit: mm

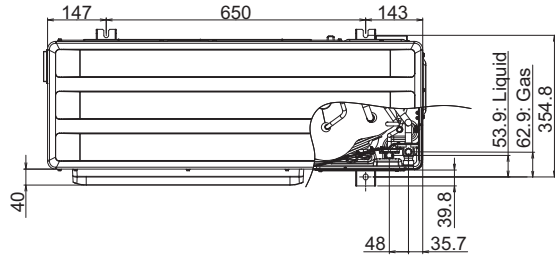

Top view

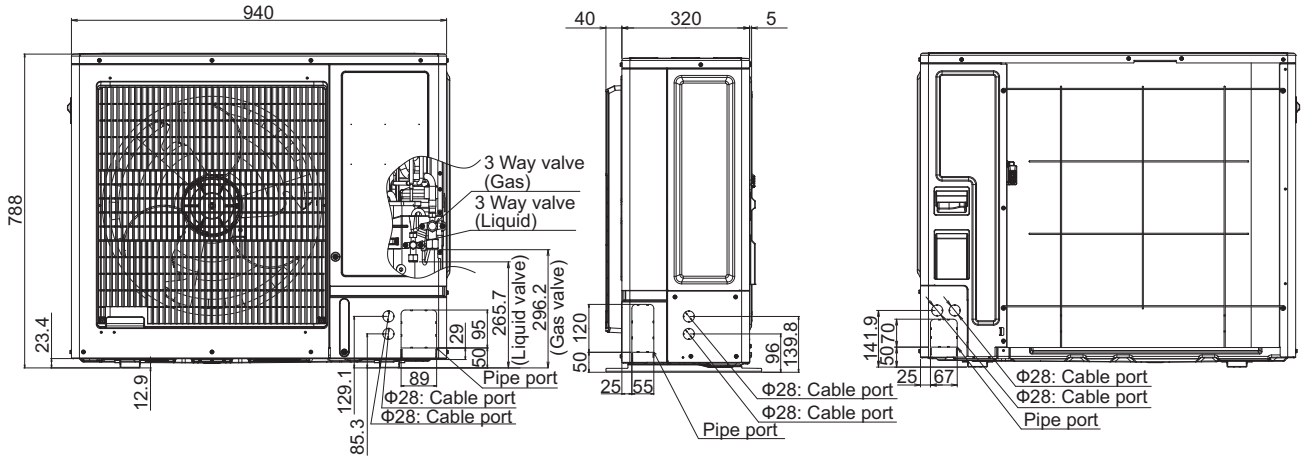

Front view

Side view

Rear view

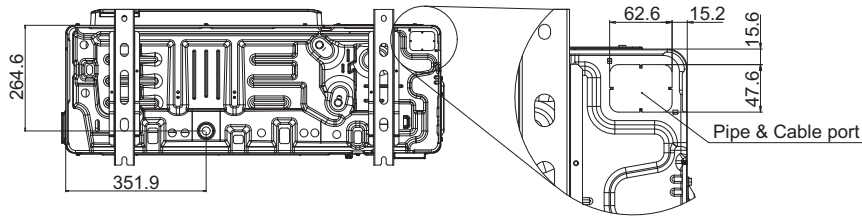

Bottom view

Model: AOYG45KATA

Unit: mm

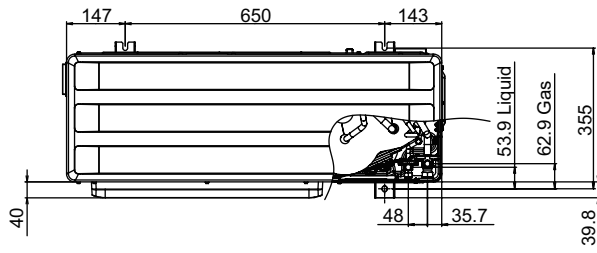

Top view

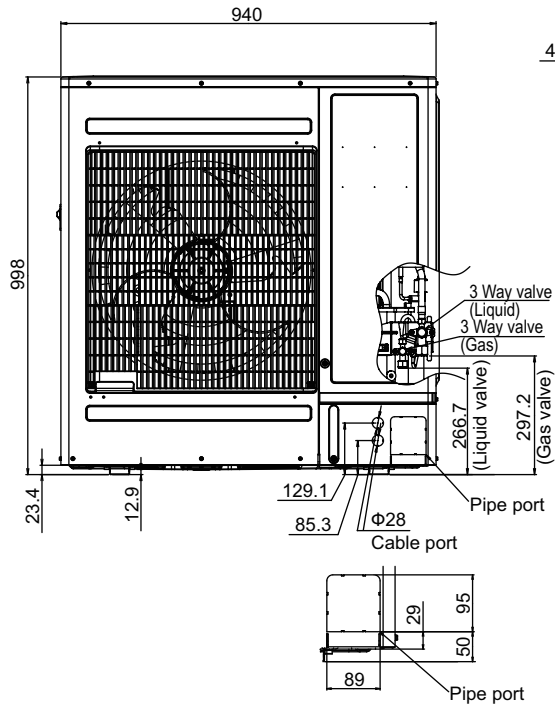

Front view

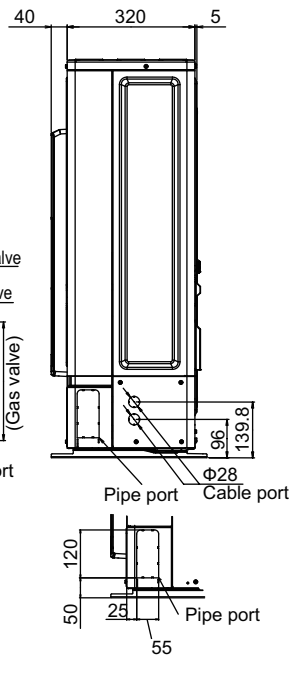

Side view

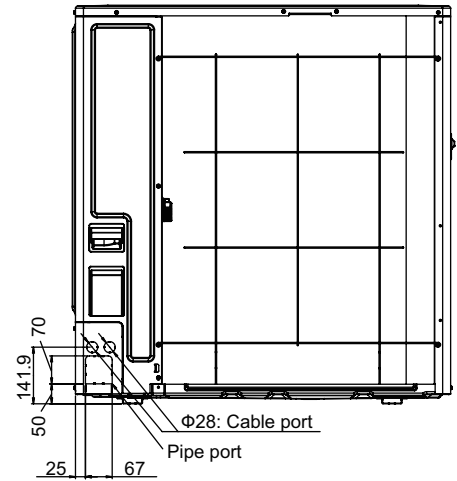

Rear view

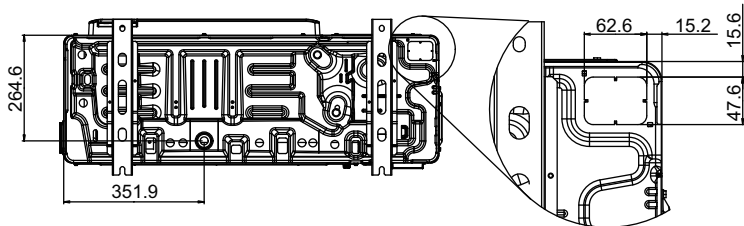

Bottom view

Pipe & Cable port

2. TECHNICAL DATA AND PARTS LIST

CONTENTS

2. TECHNICAL DATA AND PARTS LIST

1. Precautions	02-1
2. Cassette Grille (option) parts list	02-2
2-1. Model: UTG-UKYC-W	02-2
3. Indoor unit parts list	02-5
3-1. Models: AUXG24KRLB, AUXG30KRLB, AUXG36KRLB, AUXG45KRLB, and AUXG54KRLB	02-5
4. Outdoor unit parts list	02-10
4-1. Model: AOYG24KATA	02-10
4-2. Models: AOYG30KATA and AOYG36KATA.....	02-14
4-3. Models: AOYG45KATA and AOYG54KATA.....	02-18
5. Accessories	02-22
5-1. Indoor unit	02-22
5-2. Outdoor unit.....	02-23
6. Optional parts	02-24
6-1. Indoor unit	02-24
6-2. Outdoor unit.....	02-27
7. Refrigerant system diagrams	02-28
7-1. Model: AOYG24KATA	02-28
7-2. Models: AOYG30KATA, AOYG36KATA, AOYG45KATA, and AOYG54KATA	02-29
8. PC board diagrams	02-30
8-1. Models: AUXG24KRLB, AUXG30KRLB, AUXG36KRLB, AUXG45KRLB, and AUXG54KRLB	02-30
8-2. AOYG24KATA.....	02-31
8-3. Models: AOYG30KATA, AOYG36KATA, AOYG45KATA, and AOYG54KATA	02-32

1. Precautions

When you start servicing, pay attention to the following points. For detailed precautions, refer to the installation manual of the products.

CAUTION

- Service personnel
 - Any person who is involved with working on or breaking into a refrigerant circuit should hold a current valid certificate from an industry-accredited assessment authority, which authorizes their competence to handle refrigerants safely in accordance with an industry recognized assessment specification.
 - Servicing shall only be performed as recommended by the equipment manufacturer. Maintenance and repair requiring the assistance of other skilled personnel shall be carried out under the supervision of the person competent in the use of flammable refrigerants.
 - Servicing shall be performed only as recommended by the manufacturer.
 - Work
 - Prior to beginning work on systems containing flammable refrigerants, safety checks are necessary to ensure that the risk of ignition is minimized. When repairing the refrigerant system, refer to the precautions written in the installation manual of the products before you start servicing.
 - Work shall be undertaken under a controlled procedure so as to minimize the risk of a flammable gas or vapor being present while the work is being performed.
 - All maintenance staff and others working in the local area shall be instructed on the nature of work being carried out.
 - Work in confined spaces shall be avoided.
 - The area around the workspace shall be sectioned off.
 - Ensure that the conditions within the area have been made safe by control of flammable material.
 - Electric shock may occur. After turning off the power, always wait 5 minutes before touching electrical components.
 - Do not touch the fins of the heat exchanger. Touching the heat exchanger fins could result in damage to the fins or personal injury such as skin rupture.
 - Do not place any other electrical products or household belongings under the product.
 - Condensation dripping from the product might get them wet, and may cause damage or malfunction to the property.
 - Checking for presence of refrigerant
 - The area shall be checked with an appropriate refrigerant leak detector prior to and during work, to ensure the technician is aware of potentially flammable atmospheres.
 - Ensure that the leak detector being used is suitable for use with flammable refrigerants, i.e. non-sparking, adequately sealed or intrinsically safe.
-
- Service parts information and design are subject to change without notice for product improvement.
 - For the latest information of the service parts, refer to our Service Portal.
<https://fujitsu-general.force.com/portal/>
 - Precise figure of the service parts listed in this manual may differ from the actual service parts.

2. Cassette Grille (option) parts list

2-1. Model: UTG-UKYC-W

■ Intake grille

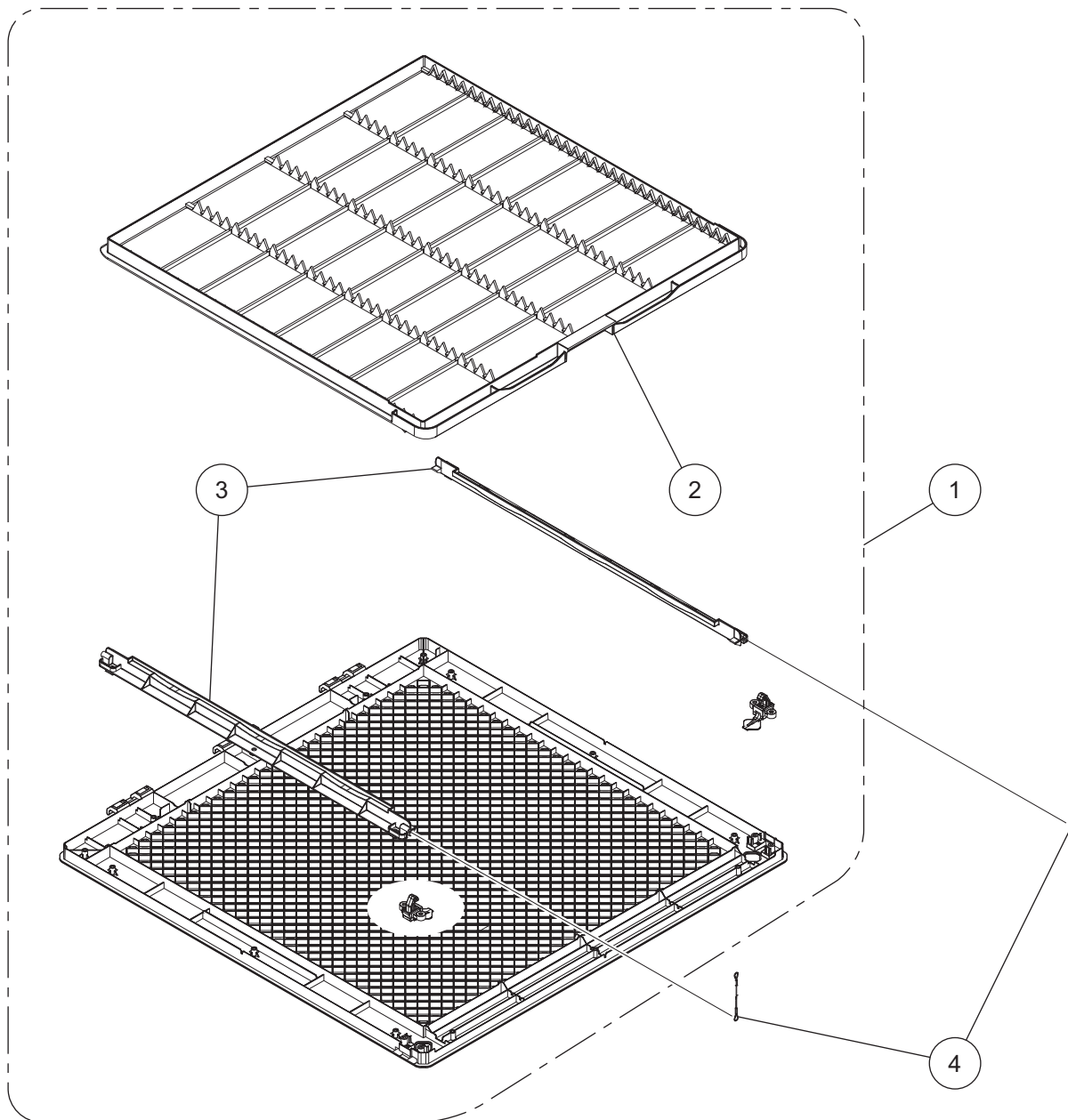

Ref No.	Description	Parts No.
1	Intake Grille Assy	9381691005
2	Long Life Filter	9378252028
3	Filter Guide	9378253018
4	Hook Wire	9378597020

■ Panels

TECHNICAL DATA
AND PARTS LIST

TECHNICAL DATA
AND PARTS LIST

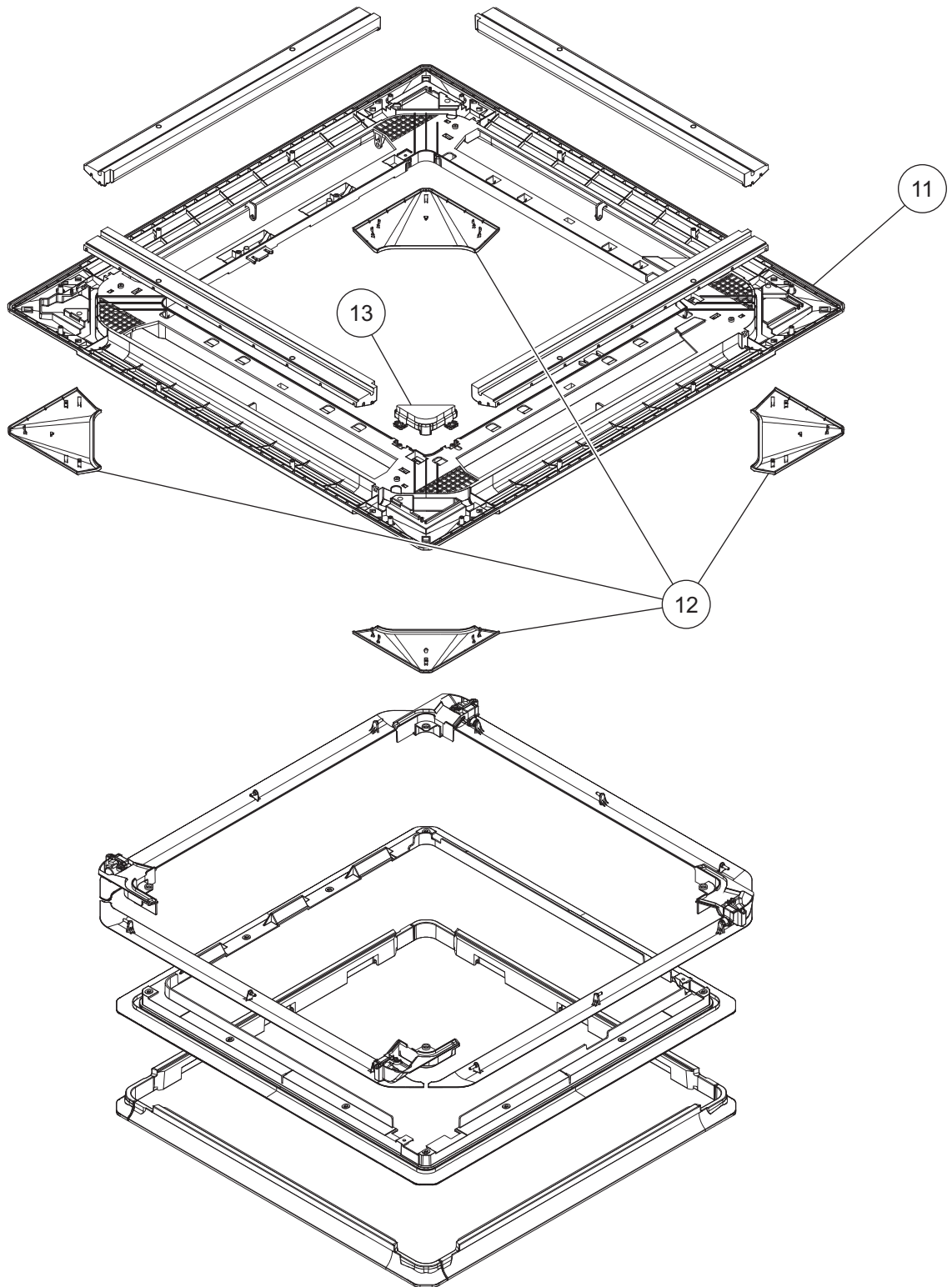

Ref No.	Description	Parts No.
11	Decoration Panel	9381352005
12	Corner Panel Assy	9381711000
13	Drain Cover Assy	9381713004

■ Louvers and motors

TECHNICAL DATA
AND PARTS LIST

TECHNICAL DATA
AND PARTS LIST

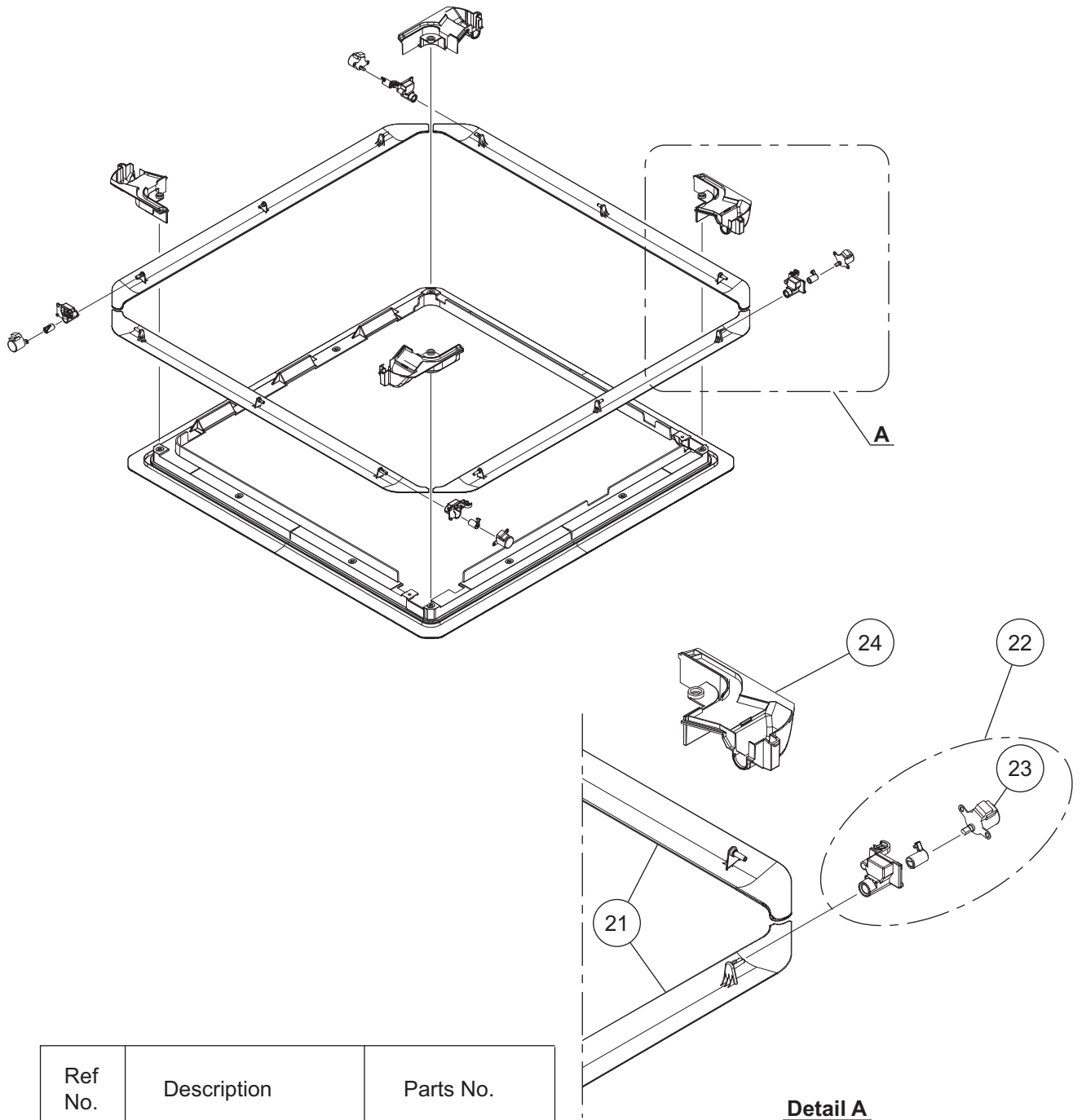

Ref No.	Description	Parts No.
21	Louver Assy	9381693009
22	Motor Case Assy	9381712007
23	Step Motor	9900885007
24	Motor Cover	9381354009
	Wire (Step Motor)	9710175008

Detail A

3. Indoor unit parts list

3-1. Models: AUXG24KRLB, AUXG30KRLB, AUXG36KRLB, AUXG45KRLB, and AUXG54KRLB

■ Miscellaneous parts

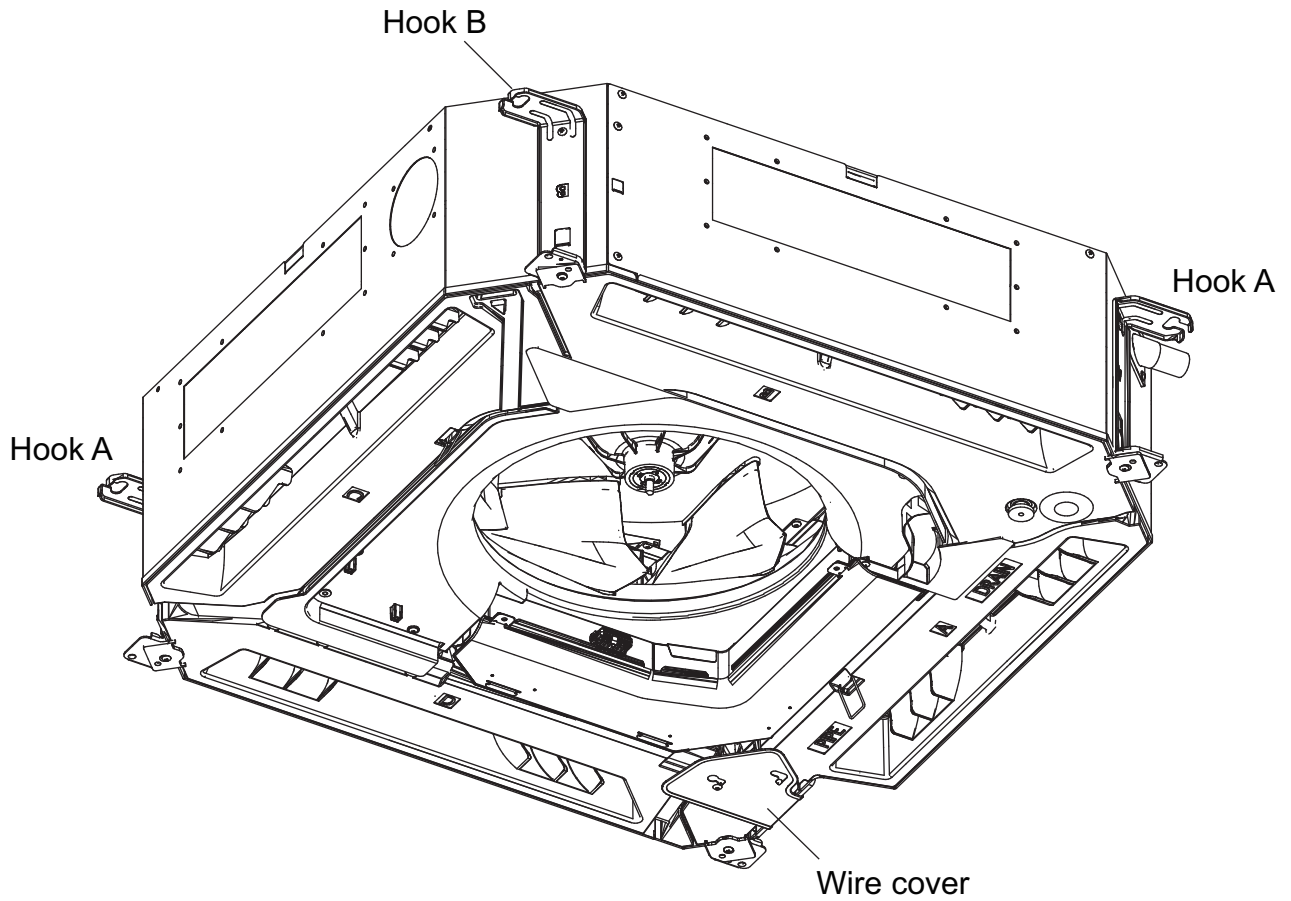

■ Main PC board

TECHNICAL DATA
AND PARTS LIST

TECHNICAL DATA
AND PARTS LIST

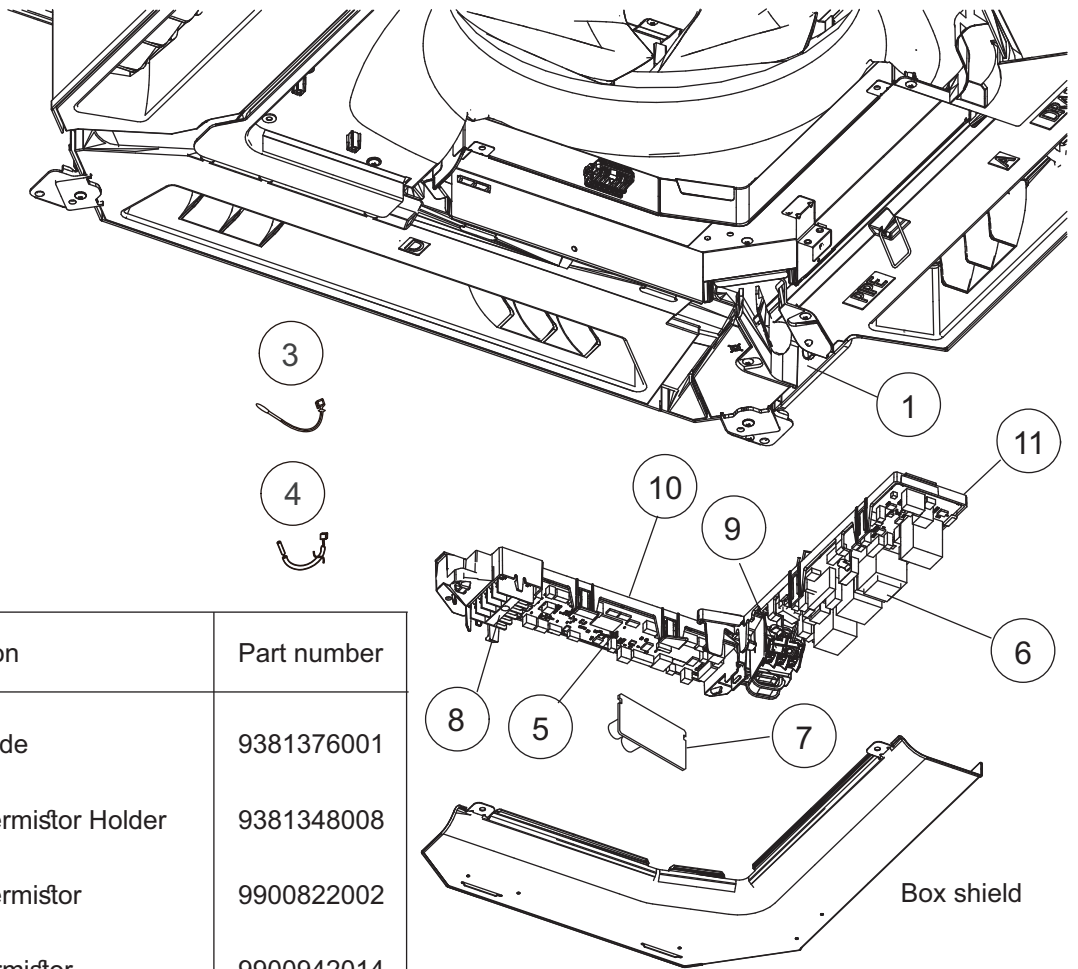

Ref.	Description	Part number
1	Cable guide	9381376001
2	Room thermistor Holder	9381348008
3	Room thermistor	9900822002
4	Pipe Thermistor	9900942014
5	Main PCB (AUXG24KRLB)	9710995873
5	Main PCB (AUXG30KRLB)	9710995880
5	Main PCB (AUXG36KRLB)	9710995897
5	Main PCB (AUXG45KRLB)	9710995903
5	Main PCB (AUXG54KRLB)	9710995910
6	Power PCB	9710022005
7	PCB (Non-polar 2-wire)	9710019005
8	Remote terminal 5P	9900896003
9	Power Terminal 3P	9900720032
10	Main PCB holder	9381350001
11	Power PCB Holder	9381349005

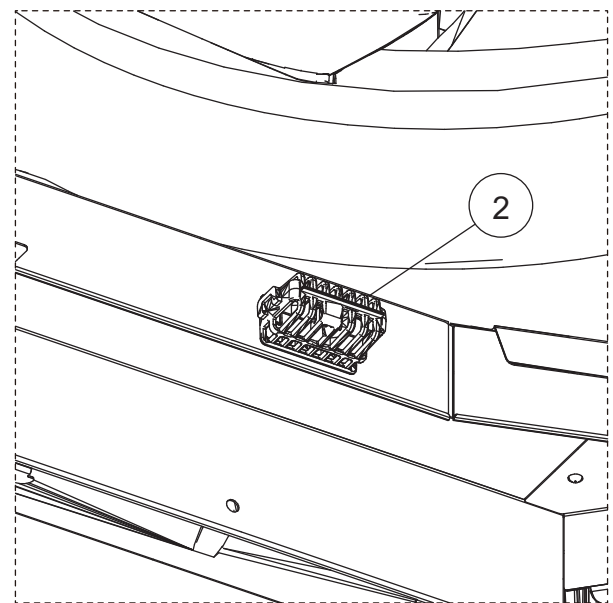

Fan and motor

TECHNICAL DATA
AND PARTS LIST

TECHNICAL DATA
AND PARTS LIST

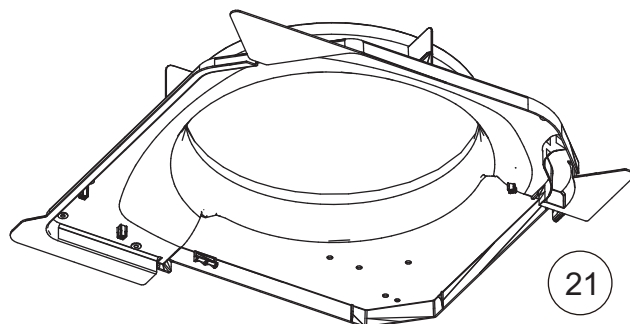
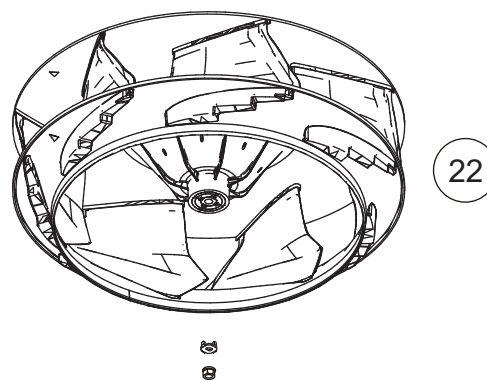
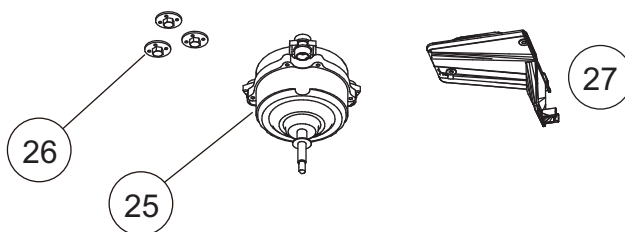
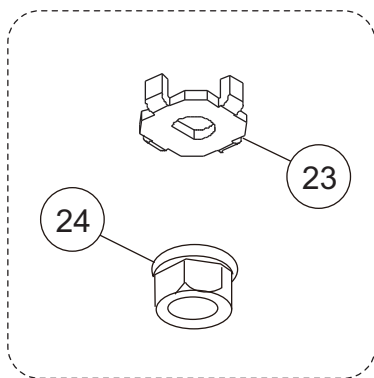
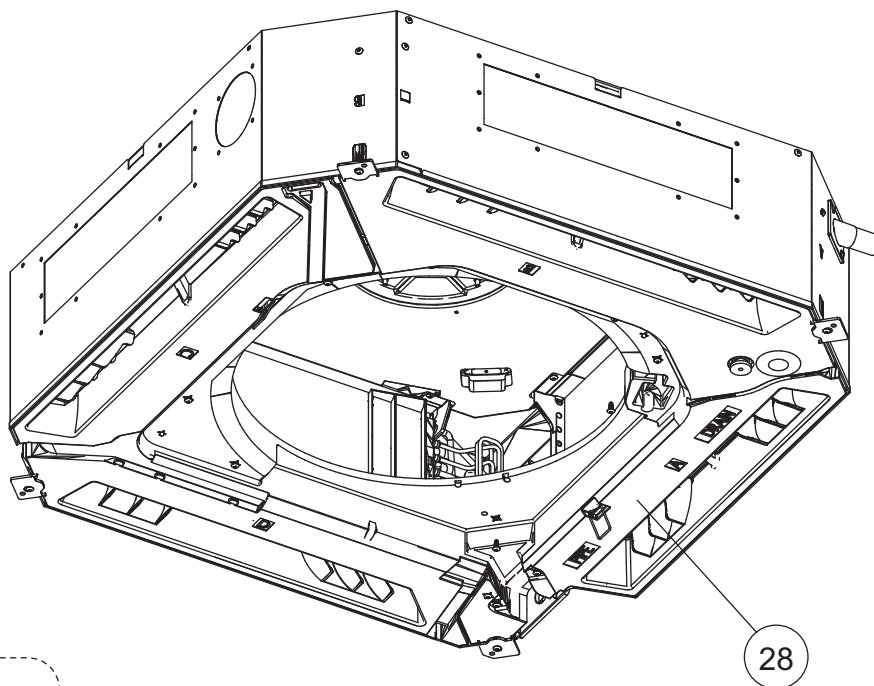

Ref.	Description	Part number
21	Bellmouth (24)	9381484003
21	Bellmouth (30,36,45,54)	9381345007
22	Turbo fan assy	9381303007
23	Turbo Fan Washer	9378394018
24	Nut	9356998009
25	Brushless motor	9603443009
26	Special Nut	9378388017
27	Motor Wire Holder	9381351008
28	Drain pan sub assy	9381789009

■ Drain pump

TECHNICAL DATA
AND PARTS LIST

TECHNICAL DATA
AND PARTS LIST

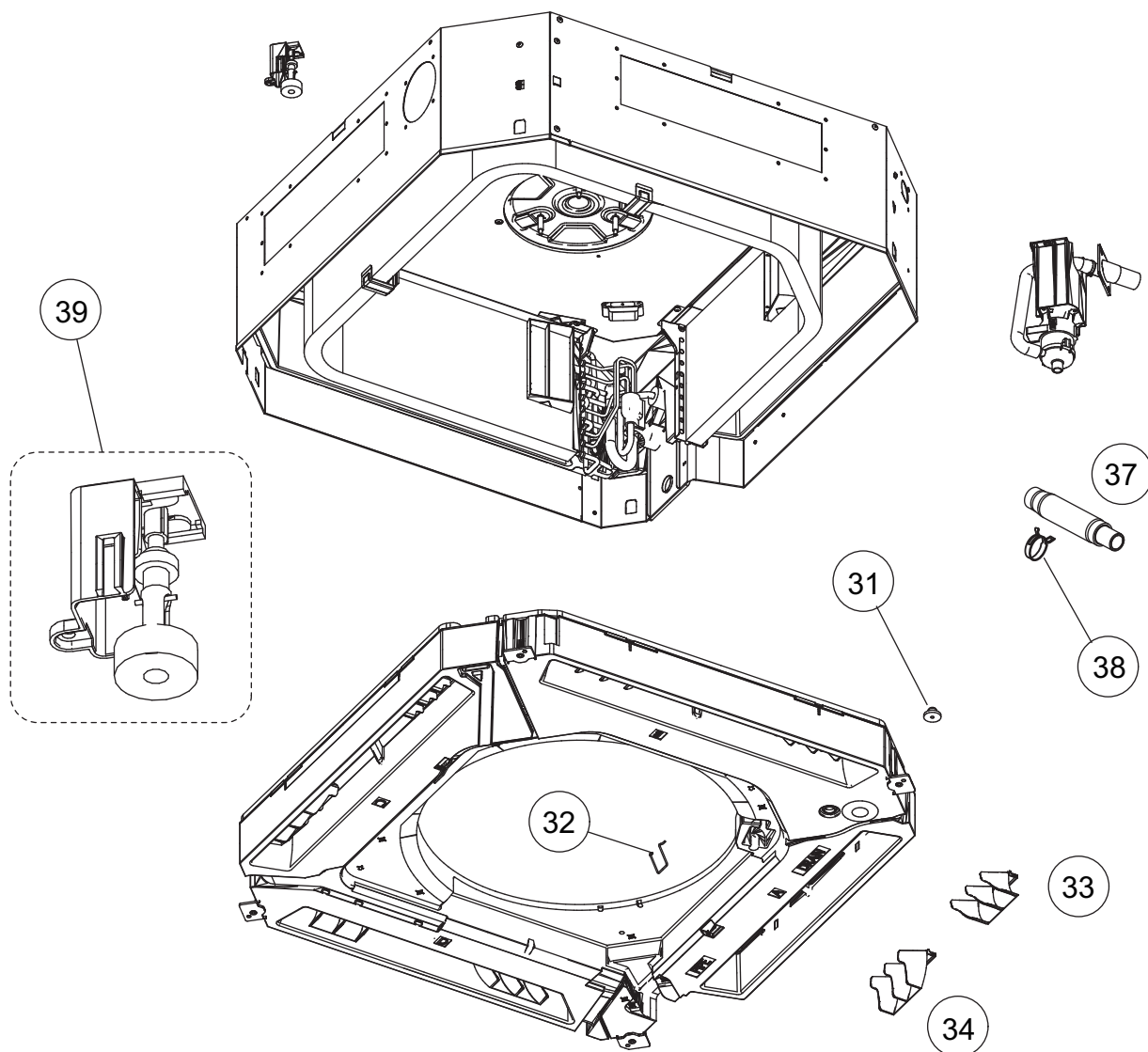

Ref.	Description	Part number
31	Drain Cap	9375502010
32	Panel Hook	9375671013
33	Vane L	9381745012
34	Vane R	9381744008
35	Drain Pump Sub Assy	9381793006
36	Drain Port Sub Assy	9381788002
37	Drain Hose	9379665001
38	Hose Band	9379757010
39	Float Switch Sub Assy	9381794003

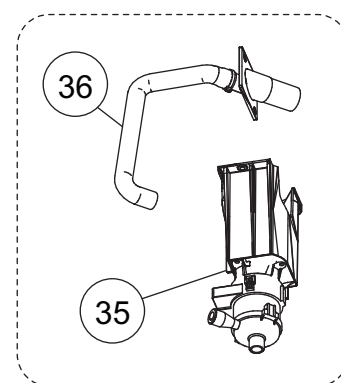

Evaporator

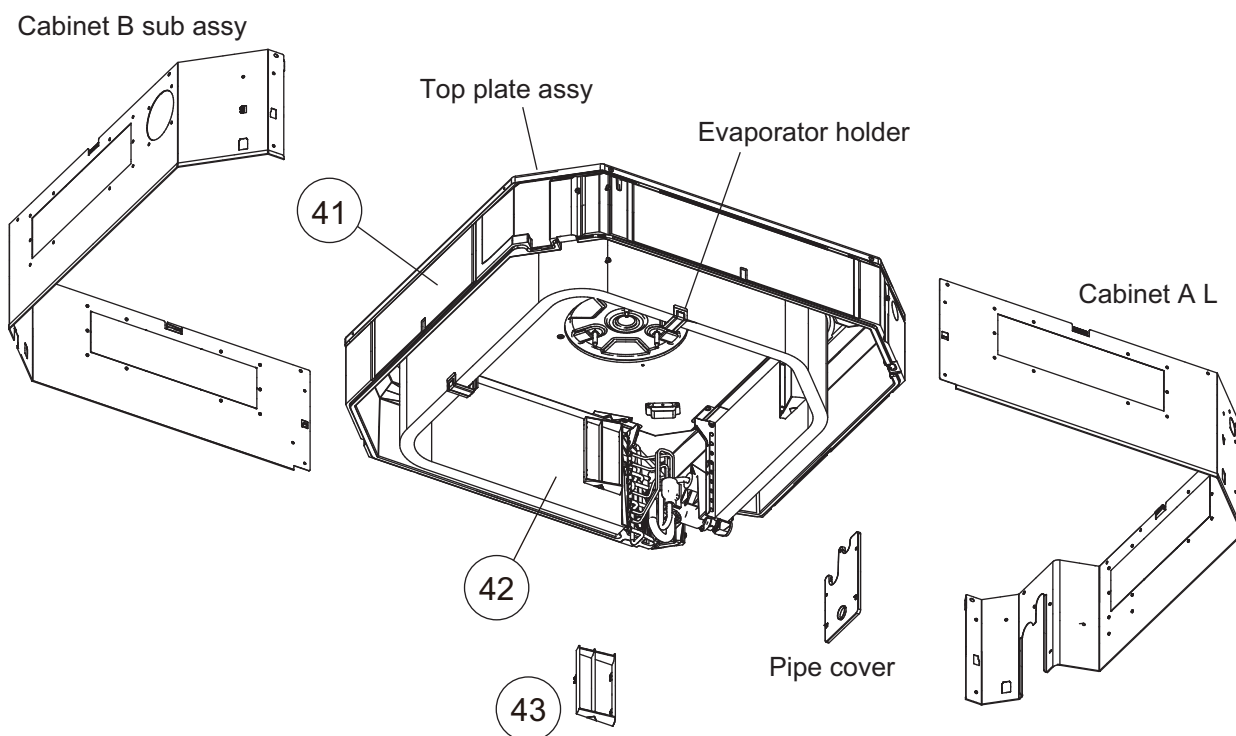

Ref.	Description	Part number
41	Insulation Box Sub Assy (24)	9381787012
41	Insulation Box Sub Assy (30,36,45,54)	9381787005
42	Evaporator Total Assy (24)	9378580664
42	Evaporator Total Assy (30)	9378580671
42	Evaporator Total Assy (36,45,54)	9378580688
43	Wind Guide Board	9382125004

4. Outdoor unit parts list

4-1. Model: AOYG24KATA

■ Exterior parts and Chassis

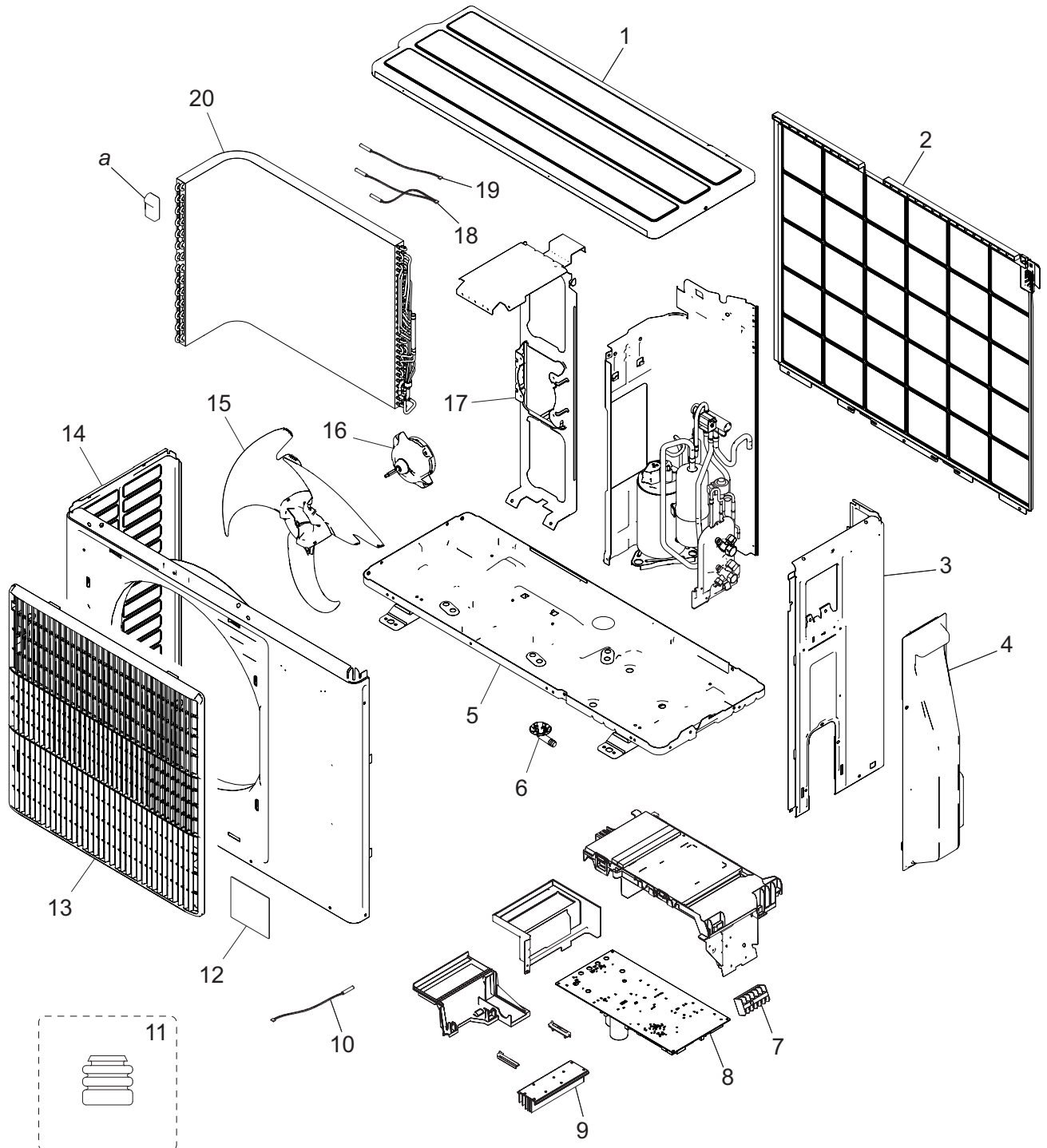

Item no.	Part no.	Part name	Service part
1	9322556028	Top panel assy	◆
2	9322811028	Protective net assy	◆
3	9322552099	Cabinet right assy	◆
4	9322570024	Switch cover assy	◆
5	9322314024	Base assy	◆
6	9322144003	Drain pipe	◆
7	9900435028	Terminal block	◆
8	9709685297	Main PCB (22 model)	◆
	9709685303	Main PCB (24 model)	◆
9	9322420039	Heat sink	◆
10	9900565060	Thermistor assy (Outdoor temp.)	◆
11	9322386007	Cushion rubber	◆
12	—	Emblem	Not available
13	9322149008	Blow grille	◆
14	9322555021	Front panel assy	◆
15	9322150004	Propeller fan	◆
16	9604091001	DC fan motor	◆
17	9322553027	Motor bracket assy	◆
18	9900727079	Thermistor assy	◆
19	9900984014	Thermistor (Heat exchanger)	◆
20	9323834194	Heat exchanger unit (22 model)	◆
	9323834330	Heat exchanger unit (24 model)	◆
<i>a</i>	—	Hair pin cushion	—

Compressor

TECHNICAL DATA
AND PARTS LIST

TECHNICAL DATA
AND PARTS LIST

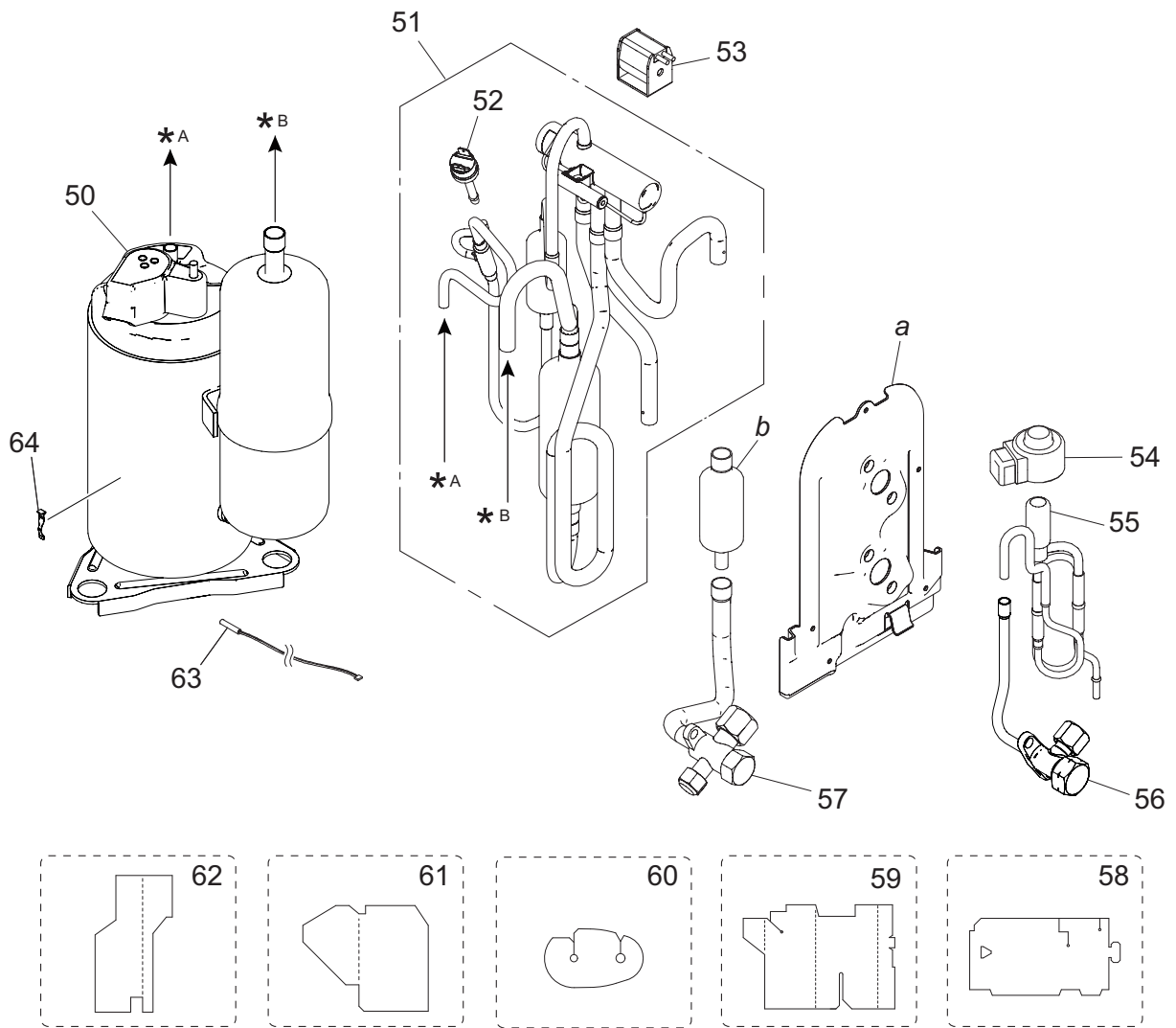

Item no.	Part no.	Part name	Service part
50	9322433008	Compressor (22 model)	◆
	9810521002	Compressor (24 model)	◆
51	9322783028	4-way valve assy (22 model)	◆
	9383129032	4-way valve assy (24 model)	◆
52	9900186029	Pressure switch (only for 24 model)	◆
53	9970110160	Solenoid	◆
54	9970222016	Expansion valve coil	◆
55	9322463029	Pulse motor valve assy	◆
56	9322474001	2-way valve assy	◆
57	9387831016	3-way valve assy	◆
58	9322500007	Sound insulator B (22 model)	◆
	9322503008	Sound insulator B (24 model)	◆
59	9322847003	Sound insulator F	◆
60	9322501004	Sound insulator H	◆
61	9323045002	Sound insulator V	◆
62	9322824004	Sound insulator K (only for 24 model)	◆
63	9900985011	Thermistor (Compressor temp.) (only for 24 model)	◆
64	9810028006	Thermistor stopper (only for 24 model)	◆
<i>a</i>	—	Valve bracket	—
<i>b</i>	—	Muffler	—

4-2. Models: AOYG30KATA and AOYG36KATA

Exterior parts and chassis

TECHNICAL DATA AND PARTS LIST

TECHNICAL DATA AND PARTS LIST

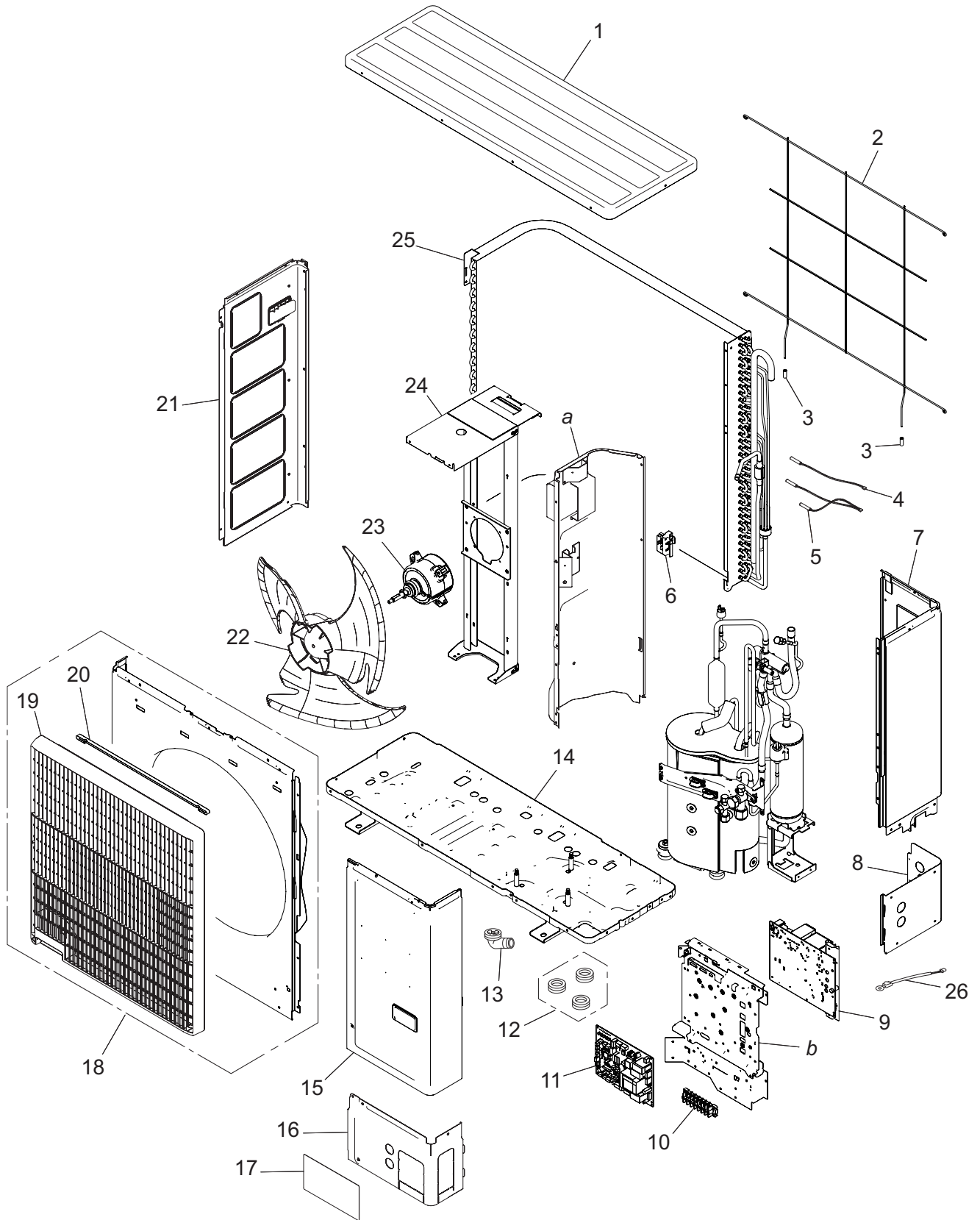

Item no.	Part no.	Part name	Service part
1	9383880001	Top panel assy	◆
2	9383779008	Protective net	◆
3	9375361013	Net rubber	◆
4	9900984038	Thermistor (Heat exchanger)	◆
5	9900727154	Thermistor assy	◆
6	9383607004	Thermistor holder	◆
7	9383874000	Right panel sub assy	◆
8	9383879005	Pipe cover (Rear)	◆
9	9709684108	Inverter PCB	◆
10	9900203061	Terminal block	◆
11	9711433039	Main PCB (30 model)	◆
	9711433046	Main PCB (36 model)	◆
12	313166024302	Drain cap	◆
13	9303029015	Drain assy	◆
14	9350255009	Base assy	◆
15	9383876004	Service panel sub assy	◆
16	9383878008	Pipe cover (Front)	◆
17	—	Emblem rear	Not available
18	9383863004	Front panel assy	◆
19	9383604003	Blow grille	◆
20	9383689000	Blow grille insulation	◆
21	9383882005	Left panel sub assy	◆
22	9383336003	Propeller fan	◆
23	9603732011	DC fan motor	◆
24	9383862007	Motor bracket assy	◆
25	9374420612	Condenser sub assy	◆
26	9901031014	Thermistor (Heat sink)	◆
—	9711332004	Wire with terminal (Power wire L)	◆
—	9711332011	Wire with terminal (Power wire N)	◆
—	9711205001	Wire with connector (P350 on Main PCB—P351 on Inverter PCB)	◆
—	9711203007	Wire with connector (P660 on Main PCB—P662 on Inverter PCB)	◆
—	9711204004	Wire with connector (P661 on Main PCB—P663 on Inverter PCB)	◆
—	9711214003	Wire with connector (Pressure switch)	◆
—	9711213006	Wire with connector (P770 on Inverter PCB [for Pressure switch])	◆
—	9711212009	Wire with connector (P650 on Inverter PCB—Fan motor)	◆
—	9711206015	Wire with terminal (P400 [U], P401 [V], P402 [W] on Inverter PCB— Compressor)	◆
<i>a</i>	—	Separate wall assy	—
<i>b</i>	—	Control box unit	—

Compressor

TECHNICAL DATA
AND PARTS LIST

TECHNICAL DATA
AND PARTS LIST

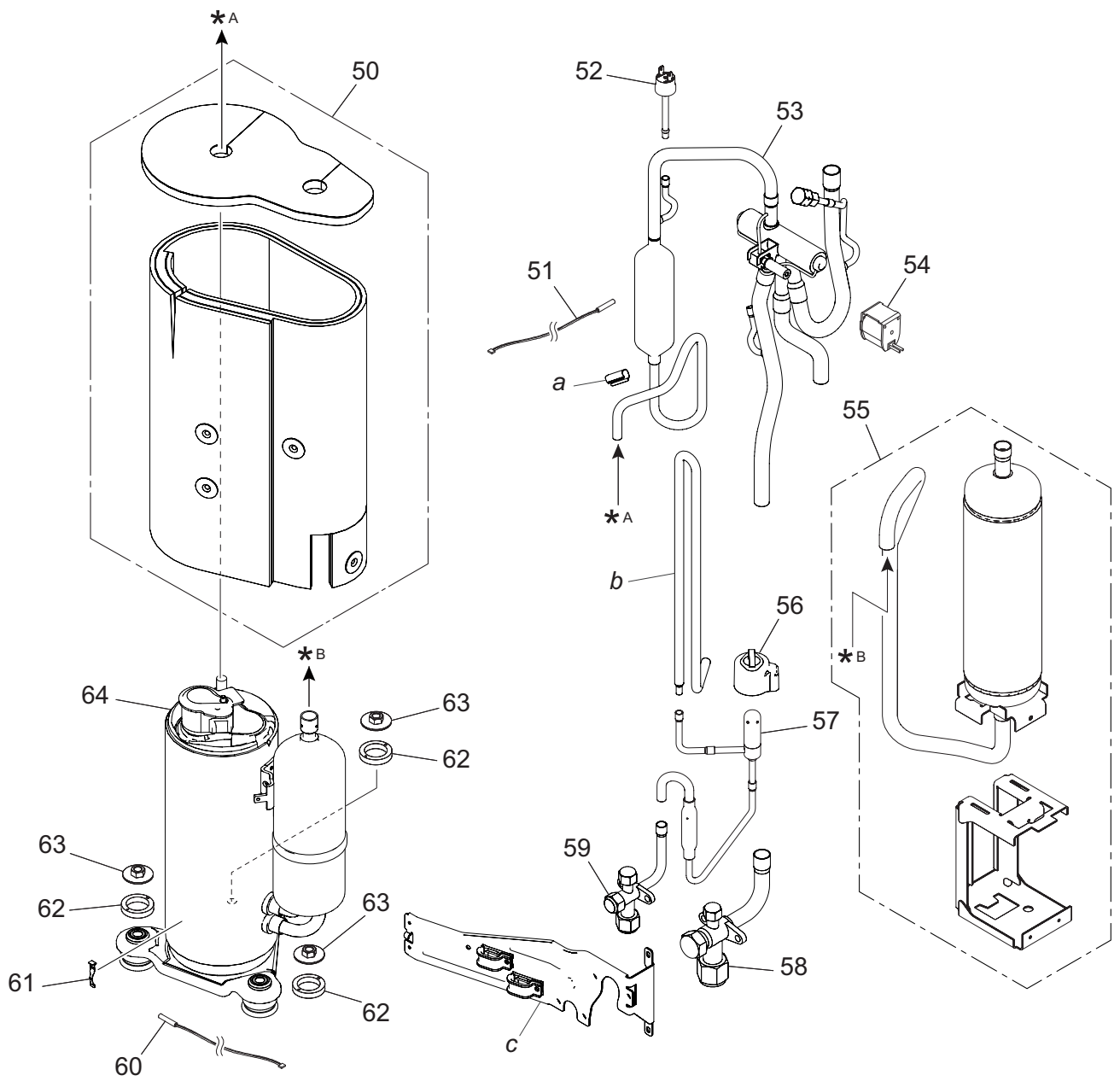

Item no.	Part no.	Part name	Service part
50	9383858000	Sound insulation unit	◆
51	9900565091	Thermistor (Outdoor temp.)	◆
52	9900186029	Pressure switch	◆
53	9374425648	4-way valve assy	◆
54	9970194016	Solenoid	◆
55	9384848017	Accumulator assy (service)	◆
56	9970209000	Expansion valve coil	◆
57	9370947328	Expansion valve assy	◆
58	9379079013	3-way valve assy	◆
59	9377958037	3-way valve assy	◆
60	9900985035	Thermistor (Compressor)	◆
61	9810028006	Thermistor stopper	◆
62	9379179072	Rubber washer E	◆
63	9377973016	Special nut	◆
64	9383821004	Compressor assy	◆
<i>a</i>	—	Thermostat holder	—
<i>b</i>	—	Joint pipe D	—
<i>c</i>	—	Wiring fixation unit	—

4-3. Models: AOYG45KATA and AOYG54KATA

■ Exterior parts and chassis

TECHNICAL DATA
AND PARTS LIST

TECHNICAL DATA
AND PARTS LIST

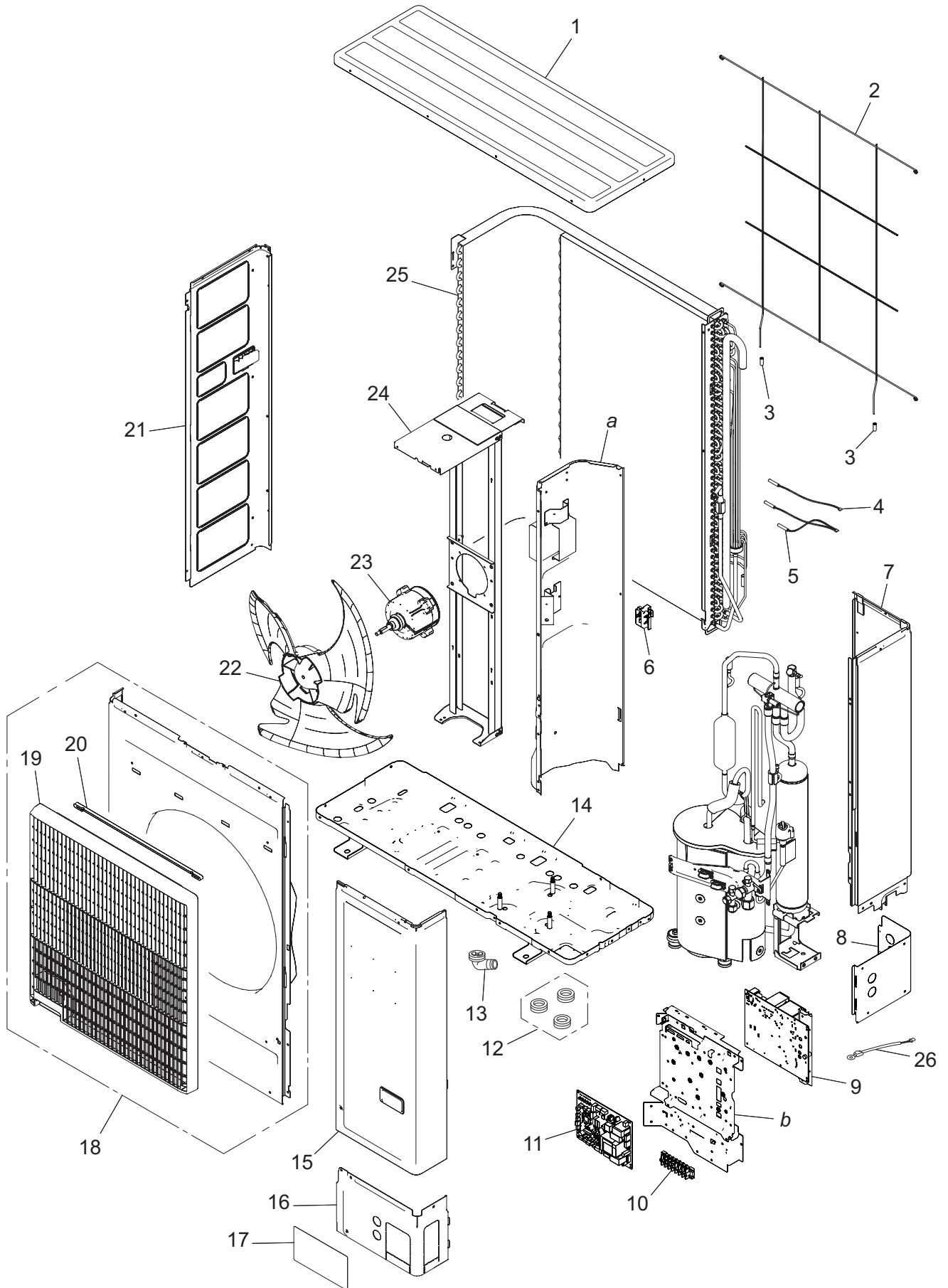

Item no.	Part no.	Part name	Service part
1	9383880001	Top panel assy	◆
2	9381013005	Protective net	◆
3	9375361013	Net rubber	◆
4	9900984038	Thermistor (Heat exchanger)	◆
5	9900727154	Thermistor assy	◆
6	9383607004	Thermistor holder	◆
7	9383874017	Right panel sub assy	◆
8	9383879005	Pipe cover (Rear)	◆
9	9709684122	Inverter PCB (45 model)	◆
	9709684115	Inverter PCB (54 model)	◆
10	9900203061	Terminal block	◆
11	9711433053	Main PCB (45 model)	◆
	9711431158	Main PCB (54 model)	◆
12	313166024302	Drain cap	◆
13	9303029015	Drain assy	◆
14	9350255009	Base assy	◆
15	9383876011	Service panel sub assy	◆
16	9383878008	Pipe cover (Front)	◆
17	—	Emblem rear	Not available
18	9383863011	Front panel assy	◆
19	9383604003	Blow grille	◆
20	9383689000	Blow grille insulation	◆
21	9383882012	Left panel sub assy	◆
22	9383336003	Propeller fan	◆
23	9603733018	DC fan motor	◆
24	9383862021	Motor bracket assy	◆
25	9374420636	Condenser sub assy	◆
26	9901031014	Thermistor (Heat sink)	◆
—	9711332004	Wire with terminal (Power wire L)	◆
—	9711332011	Wire with terminal (Power wire N)	◆
—	9711205001	Wire with connector (P350 on Main PCB—P351 on Inverter PCB)	◆
—	9711203007	Wire with connector (P660 on Main PCB—P662 on Inverter PCB)	◆
—	9711204004	Wire with connector (P661 on Main PCB—P663 on Inverter PCB)	◆
—	9711214003	Wire with connector (Pressure switch)	◆
—	9711213006	Wire with connector (P770 on Inverter PCB [for Pressure switch])	◆
—	9711212009	Wire with connector (P650 on Inverter PCB—Fan motor)	◆
—	9711206008	Wire with terminal (P400 [U], P401 [V], P402 [W] on Inverter PCB— Compressor)	◆
<i>a</i>	—	Separate wall assy	—
<i>b</i>	—	Control box unit	—

Compressor

TECHNICAL DATA
AND PARTS LIST

TECHNICAL DATA
AND PARTS LIST

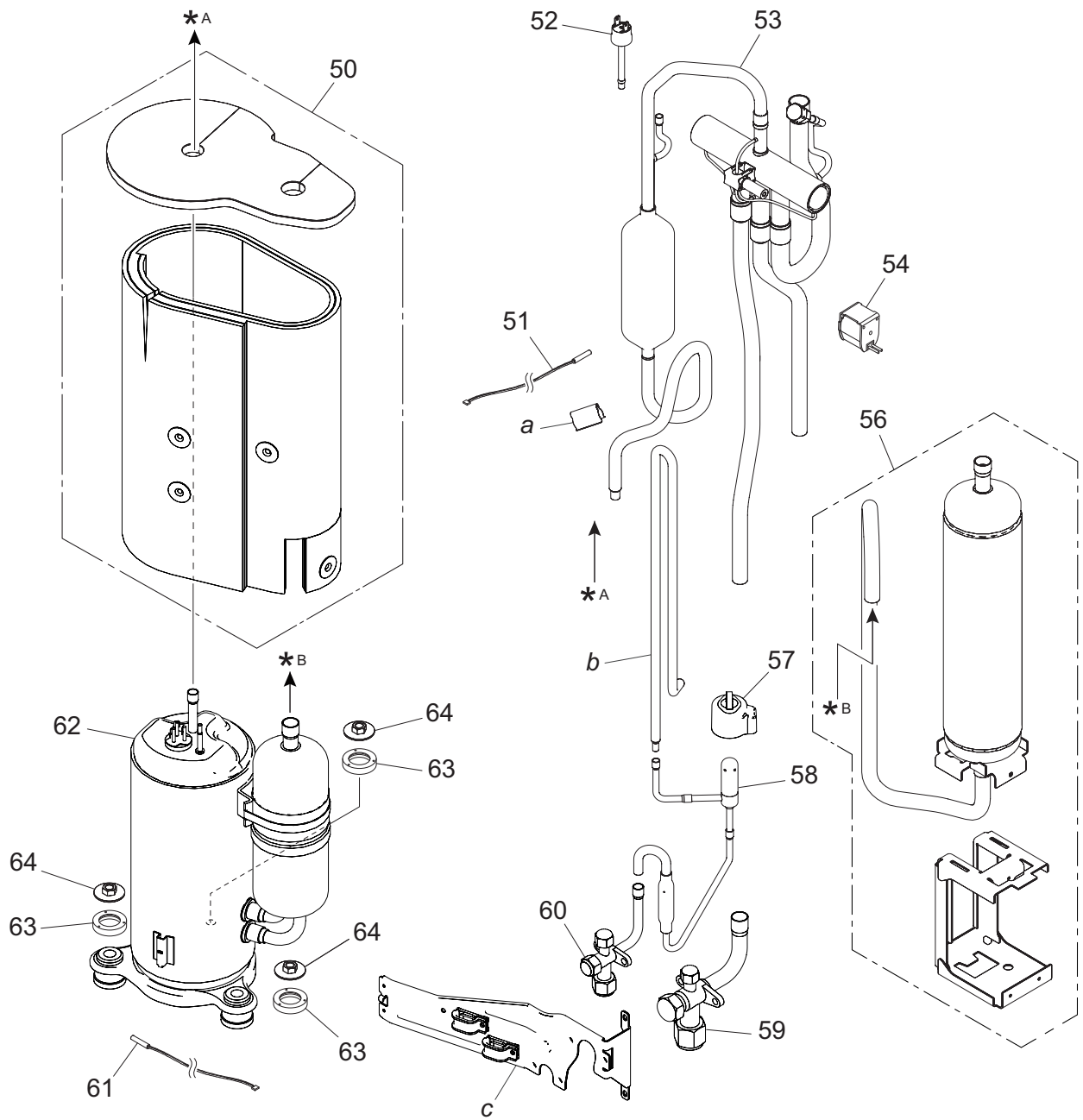







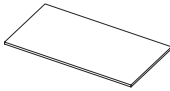
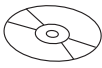
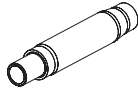

Item no.	Part no.	Part name	Service part
50	9383858017	Sound insulation unit	◆
51	9900565091	Thermistor (Outdoor temp.)	◆
52	9900186029	Pressure switch	◆
53	9374425662	4-way valve assy (for 45 model)	◆
	9374425655	4-way valve assy (for 54 model)	◆
54	9970194016	Solenoid	◆
56	9384848024	Accumulator assy (Service)	◆
57	9970209000	Expansion valve coil	◆
58	9370947311	Expansion valve assy	◆
59	9379079013	3-way valve assy	◆
60	9377958037	3-way valve assy	◆
61	9900985028	Thermistor (Compressor)	◆
62	9810621009	Compressor (for 45 model)	◆
	9810620002	Compressor (for 54 model)	◆
63	9379179089	Rubber washer F	◆
64	9377973016	Special nut	◆
<i>a</i>	—	Thermistor spring	—
<i>b</i>	—	Joint pipe D	—
<i>c</i>	—	Wiring fixation unit	—

5. Accessories

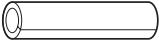

5-1. Indoor unit

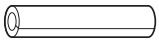
■ Models: AUXG24KRLB, AUXG30KRLB, AUXG36KRLB, AUXG45KRLB, and AUXG54KRLB





Part name	Exterior	Qty	Part name	Exterior	Qty
Operation manual		1	Insulation		1
Operation manual (CD-ROM)		1	Drain hose		1
Installation manual		1	Hose band		1
Template (Carton top)		1	Drain hose heat insulation		1
Washer		8	Cable tie (large)		4
Coupler heat insulation (large)		1	Cable tie (small)		2
Coupler heat insulation (small)		1			

5-2. Outdoor unit

■ Model: AOYG24KATA

Part name	Exterior	Qty	Part name	Exterior	Qty
Installation manual		1	Drain pipe		1



■ Models: AOYG30KATA, AOYG36KATA, AOYG45KATA, and AOYG54KATA

Part name	Exterior	Qty	Part name	Exterior	Qty
Installation manual		1	Drain cap		3
Drain pipe		1	One-touch bush		2

6. Optional parts

6-1. Indoor unit

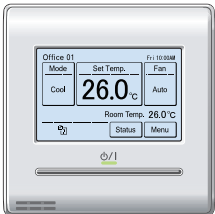
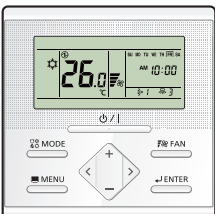
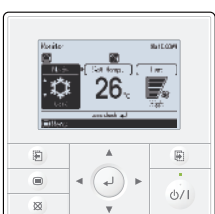
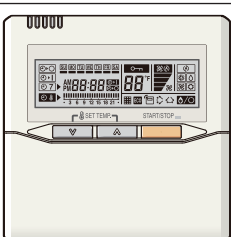

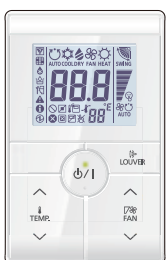
■ Controllers

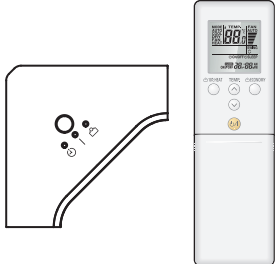
Exterior	Part name	Model name	Summary
	Wired Remote Controller	UTY-RNRYZ*	Easy finger touch operation with LCD panel. Backlit LCD enables easy operation in a dark room. Wire type: Non-polar 2-wire
	Wired Remote Controller	UTY-RLRY	High visibility and easy operation. Room temperature can be accurately controlled using the thermo sensor. Wire type: Non-polar 2-wire
	Wired Remote Controller	UTY-RVNYM	Large and full-dot liquid crystal screen, wide and large keys easy to press, user-intuitive arrow key. Wire type: Polar 3-wire
	Wired Remote Controller	UTY-RNNYM	Room temperature can be controlled by detecting the temperature accurately with thermo sensor. Wire type: Polar 3-wire
	Simple Remote Controller	UTY-RSRY	Compact remote controller concentrates on the basic functions such as Start/Stop, fan control, temperature setting, and operation mode. Wire type: Non-polar 2-wire
	Simple Remote Controller	UTY-RHRY	Compact remote controller concentrates on the basic functions such as Start/Stop, fan control, and temperature setting. Wire type: Non-polar 2-wire



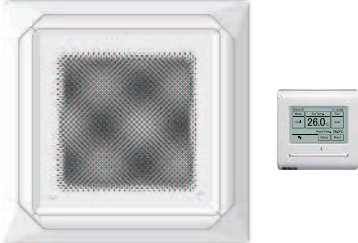
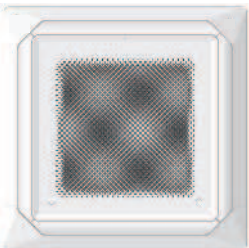

Exterior	Part name	Model name	Summary
	Simple Remote Controller	UTY-RSNYM	Compact remote controller concentrates on the basic functions such as Start/Stop, fan control, temperature setting, and operation mode. Wire type: Polar 3-wire
	IR Receiver Kit with Wireless Remote Controller	UTY-LBTYC	Unit control is performed by Wireless Remote Controller.





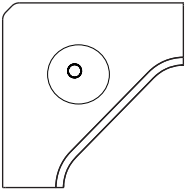
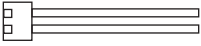

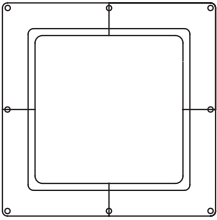
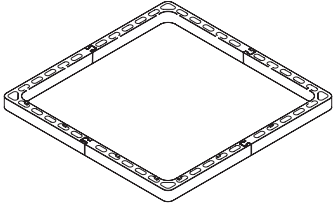
NOTE: Available functions may differ by the remote controller. For details, refer to the operation manual.

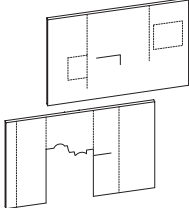
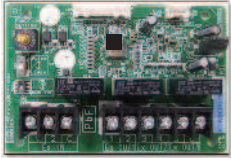
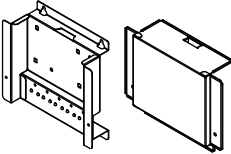
■ Cassette grille

Exterior	Part name	Model name	Summary
	Cassette Grille	UTG-UKYA-W	This cassette grille to blow airflow in 360° direction by unique seamless airflow louver design. Wired remote controller (UTY-RNRYZ*) is included.
	Cassette Grille	UTG-UKYC-W	This cassette grille to blow airflow in 360° direction by unique seamless airflow louver design.
	Cassette Grille	UTG-UKYA-B	This cassette grille to blow airflow in 360° direction by unique seamless airflow louver design. Black color model.

Others

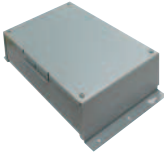
Exterior	Part name	Model name	Summary
	Human Sensor Kit	UTY-SHZXC	For circular flow cassette type.
	External Connect Kit	UTY-XWZXZG	Use to connect with various peripheral devices and air conditioner PCB. For control output port.
	Air Outlet Shutter Plate	UTR-YDZK	Installed at the air outlet when 3-directions mode is performed.
	Wide Panel	UTG-AKXA-W	Hides the gap between the ceiling hole and the cassette grille.
	Panel Spacer	UTG-BKXA-W	If there is not enough height in the ceiling space, by inserting this spacer between the cassette grille and the ceiling surface, the height of the unit body goes into the ceiling space become 50-mm lower.
	Fresh Air Intake Kit	UTZ-VXRA	By attaching Fresh Air Intake Kit to the indoor unit, it can be taken in fresh air of up to 10% of "high" air volume of the indoor unit.
	Insulation Kit for High Humidity	UTZ-KXRA	Install when the under-roof condition is expected to be the humidity of over 80% and the temperature of over 30 °C.
	External Input and Output PCB	UTY-XCSX	Use to connect with external devices and air conditioner PCB. Optional External Connect Kit is necessary for installation.
	External Input and Output PCB Box	UTZ-GXRA	For installing the External input and output PCB.

Exterior	Part name	Model name	Summary
	WLAN Adapter	UTY-TFSXZ1	Remotely manage an air conditioning system using mobile devices such as smartphones and tablets. For connection indoor unit with UART interface. Appropriate application for each region is required to use this option. For details, contact FGL sales company.
	Modbus Converter	UTY-VMSX	For connection between indoor unit with UART interface and a Modbus open network.
	KNX Converter	UTY-VKSX	For connection between indoor unit with UART interface and a KNX open network.
	Network Converter	UTY-VTGX	This converter is required when connecting single split system to VRF network system.
	Network Converter (AC power supply)	UTY-VTGXV	This converter is required when connecting single split system to VRF network system.
	External Switch Controller	UTY-TERX	Air conditioner switching can be controlled by connecting other external sensor switches.

NOTE: Combined use of following optional parts and WLAN Adapter is not allowed.

- External Input and Output PCB (UTY-XCSX)
- Modbus Converter
- KNX Converter

6-2. Outdoor unit

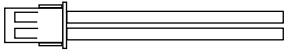
Exterior	Part name	Model name	Summary
	External Connect Kit	UTY-XWZXZ3	Use to operate the external input and output functions of outdoor unit.

7. Refrigerant system diagrams

7-1. Model: AOYG24KATA

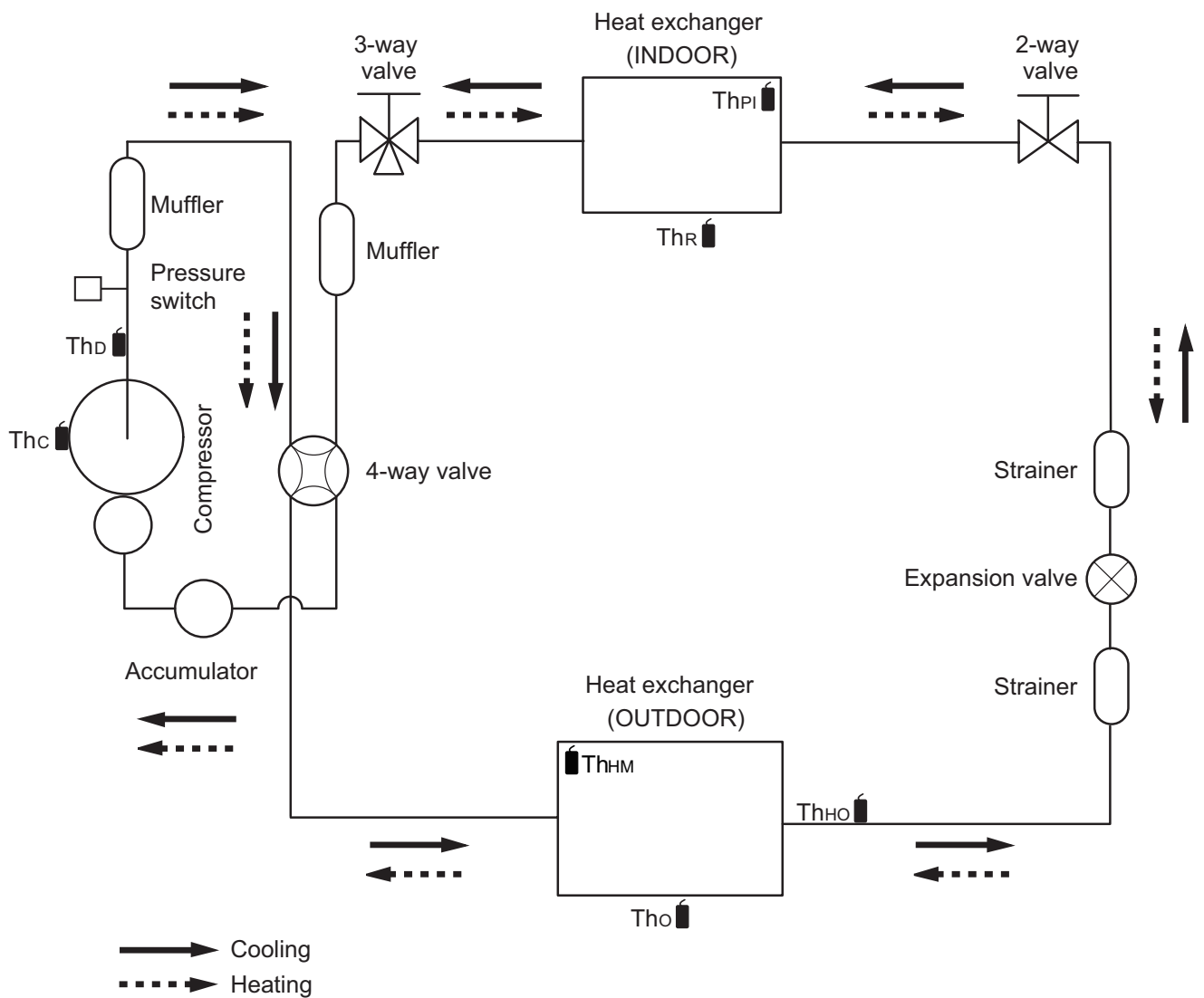

- Thc : Thermistor (Compressor temperature)
- ThD : Thermistor (Discharge temperature)
- ThHM : Thermistor (Heat exchanger middle temperature)
- Tho : Thermistor (Outdoor temperature)
- ThHO : Thermistor (Heat exchanger out temperature)
- ThPI : Thermistor (Pipe temperature)
- ThR : Thermistor (Room temperature)

7-2. Models: AOYG30KATA, AOYG36KATA, AOYG45KATA, and AOYG54KATA

TECHNICAL DATA
AND PARTS LIST

TECHNICAL DATA
AND PARTS LIST

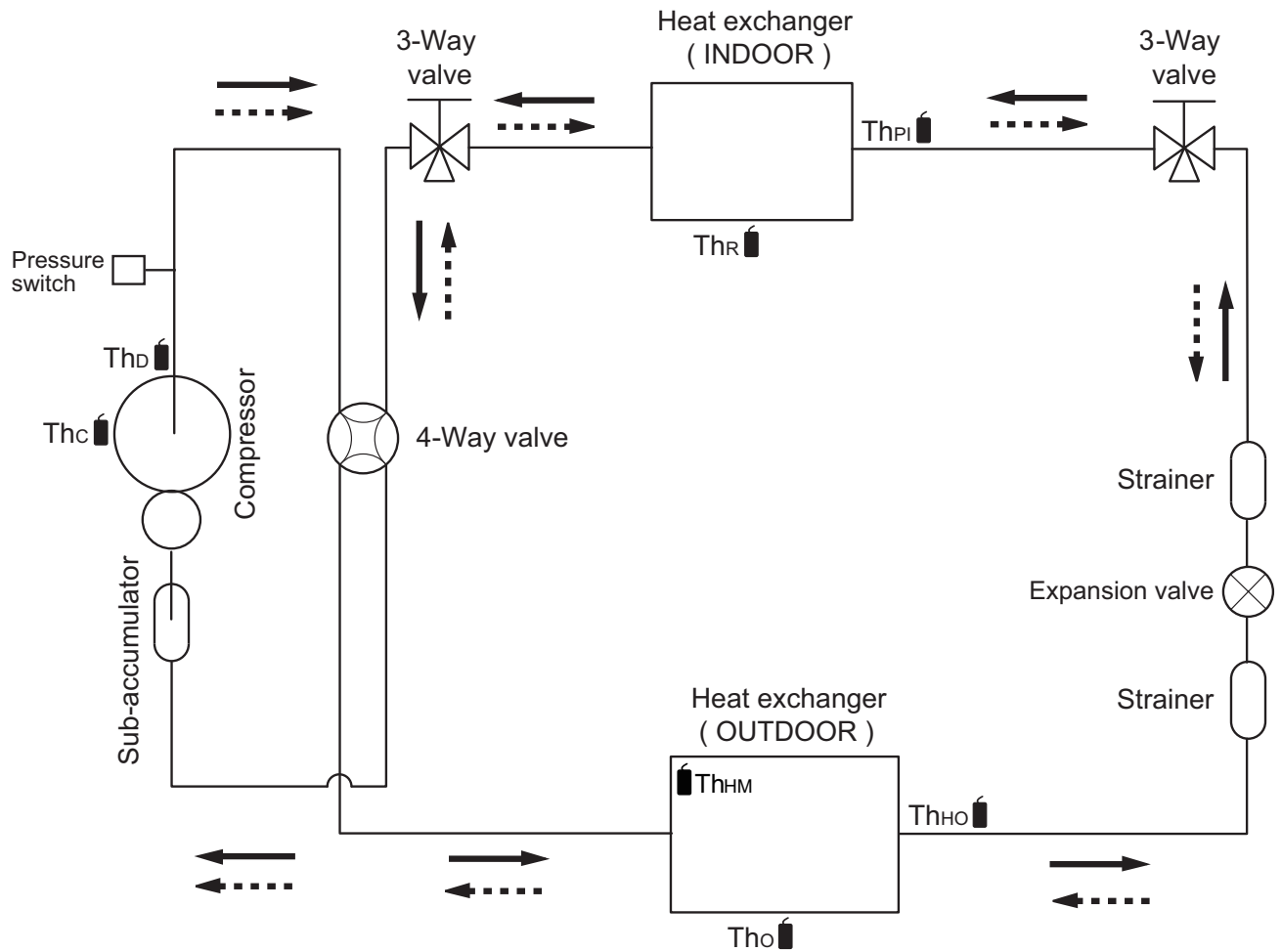

—→ : Cooling
 - - - -> : Heating

- Th_c : Thermistor (Compressor temperature)
- Th_d : Thermistor (Discharge temperature)
- Th_o : Thermistor (Outdoor temperature)
- Th_{HO} : Thermistor (Heat exchanger out temperature)
- Th_{HM} : Thermistor (Heat exchanger middle temperature)
- Th_R : Thermistor (Room temperature)
- Th_{PI} : Thermistor (Pipe temperature)

8. PC board diagrams

8-1. Models: AUXG24KRLB, AUXG30KRLB, AUXG36KRLB, AUXG45KRLB, and AUXG54KRLB

TECHNICAL DATA AND PARTS LIST

TECHNICAL DATA AND PARTS LIST

CONTROL UNIT
 24 model: EZ-01823HSE 45 model: EZ-01826HSE
 30 model: EZ-01824HSE 54 model: EZ-01827HSE
 36 model: EZ-01825HSE

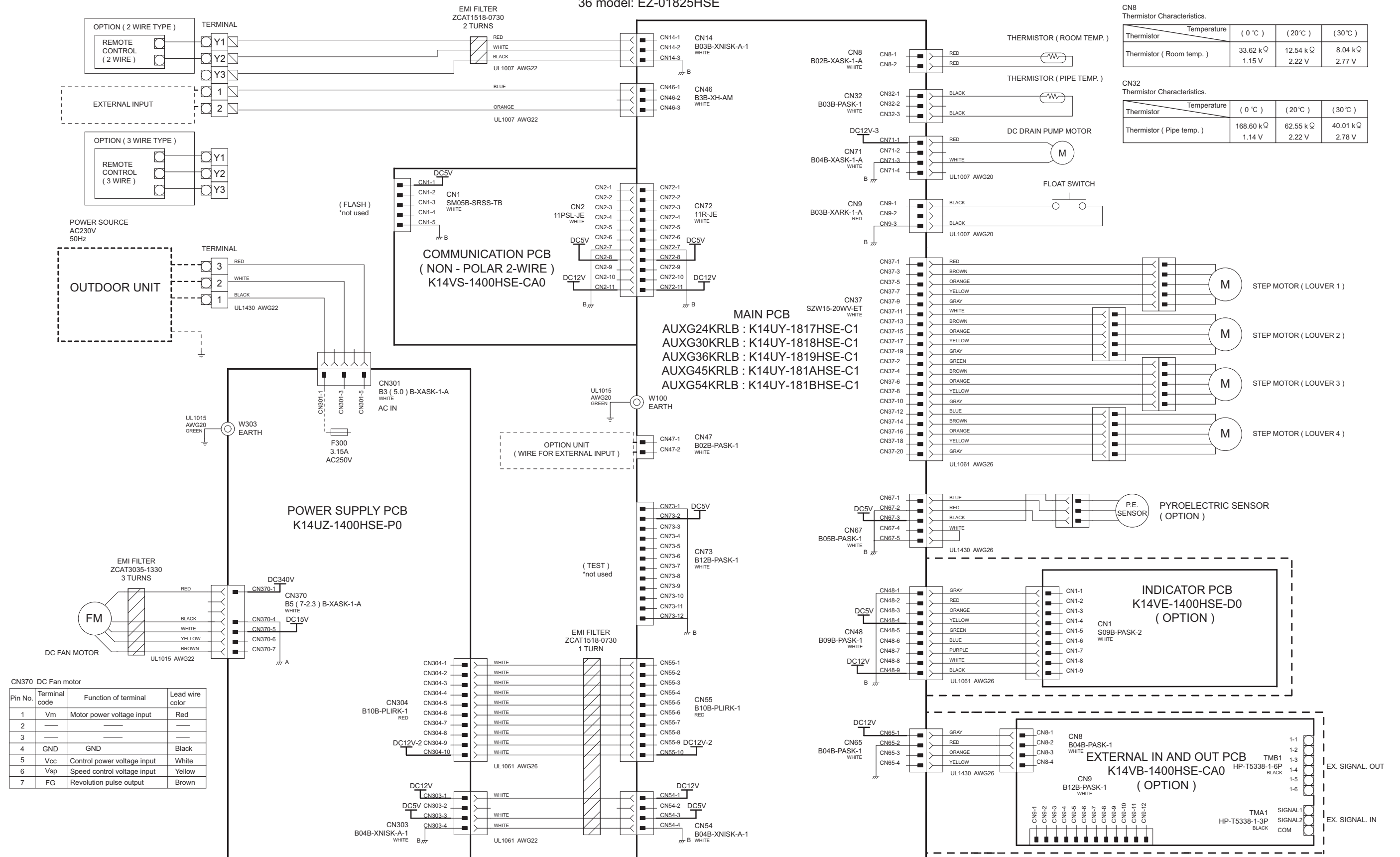

CN8 Thermistor Characteristics.

Thermistor	Temperature	(0 °C)	(20 °C)	(30 °C)
Thermistor (Room temp.)		33.62 kΩ	12.54 kΩ	8.04 kΩ
		1.15 V	2.22 V	2.77 V

CN32 Thermistor Characteristics.

Thermistor	Temperature	(0 °C)	(20 °C)	(30 °C)
Thermistor (Pipe temp.)		168.60 kΩ	62.55 kΩ	40.01 kΩ
		1.14 V	2.22 V	2.78 V

CN370 DC Fan motor

Pin No.	Terminal code	Function of terminal	Lead wire color
1	Vm	Motor power voltage input	Red
2	—	—	—
3	—	—	—
4	GND	GND	Black
5	Vcc	Control power voltage input	White
6	Vsp	Speed control voltage input	Yellow
7	FG	Revolution pulse output	Brown

8-2. AOYG24KATA

INVERTER ASSEMBLY EZ-019FHUE

TECHNICAL DATA
AND PARTS LIST

TECHNICAL DATA
AND PARTS LIST

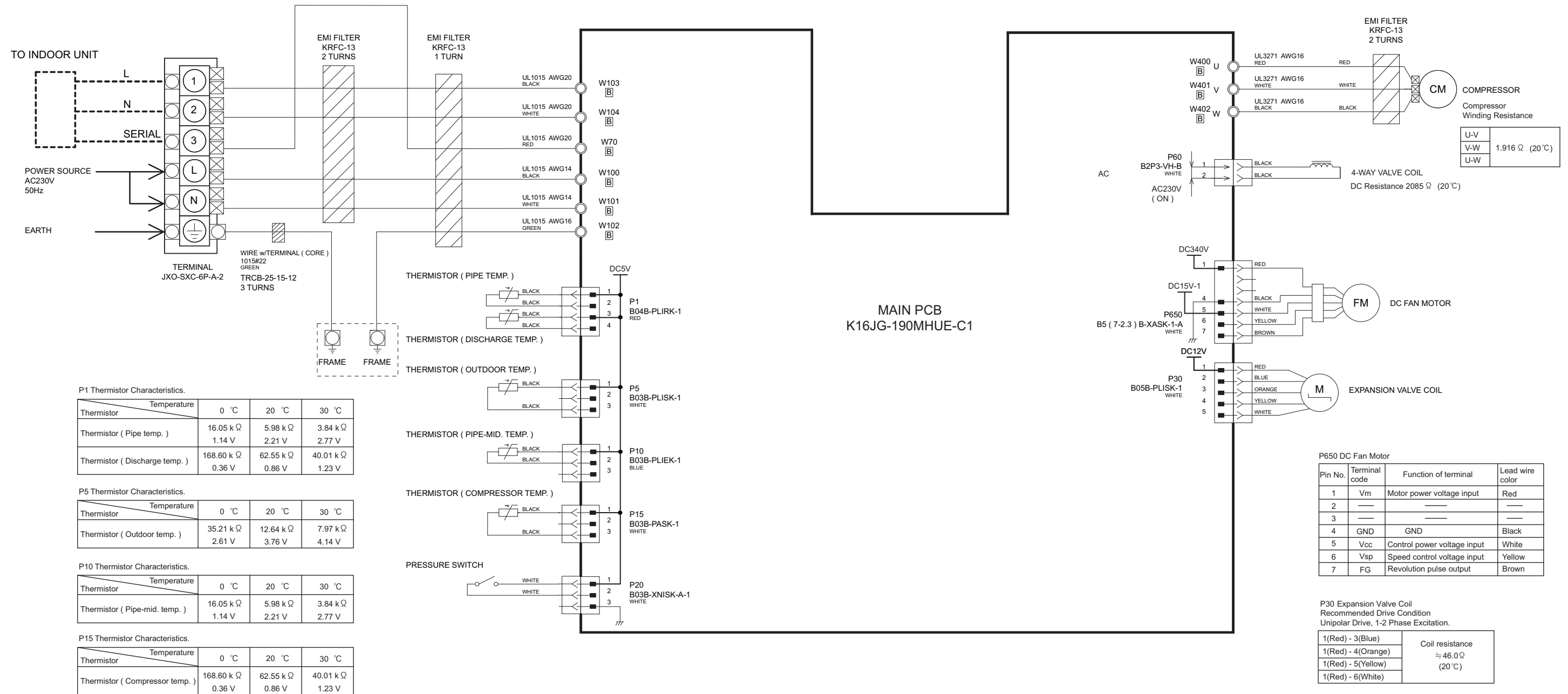

P1 Thermistor Characteristics.

Thermistor	Temperature	0 °C	20 °C	30 °C
Thermistor (Pipe temp.)		16.05 kΩ	5.98 kΩ	3.84 kΩ
		1.14 V	2.21 V	2.77 V
Thermistor (Discharge temp.)		168.60 kΩ	62.55 kΩ	40.01 kΩ
		0.36 V	0.86 V	1.23 V

P5 Thermistor Characteristics.

Thermistor	Temperature	0 °C	20 °C	30 °C
Thermistor (Outdoor temp.)		35.21 kΩ	12.64 kΩ	7.97 kΩ
		2.61 V	3.76 V	4.14 V

P10 Thermistor Characteristics.

Thermistor	Temperature	0 °C	20 °C	30 °C
Thermistor (Pipe-mid. temp.)		16.05 kΩ	5.98 kΩ	3.84 kΩ
		1.14 V	2.21 V	2.77 V

P15 Thermistor Characteristics.

Thermistor	Temperature	0 °C	20 °C	30 °C
Thermistor (Compressor temp.)		168.60 kΩ	62.55 kΩ	40.01 kΩ
		0.36 V	0.86 V	1.23 V

P650 DC Fan Motor

Pin No.	Terminal code	Function of terminal	Lead wire color
1	Vm	Motor power voltage input	Red
2	—	—	—
3	—	—	—
4	GND	GND	Black
5	Vcc	Control power voltage input	White
6	Vsp	Speed control voltage input	Yellow
7	FG	Revolution pulse output	Brown

P30 Expansion Valve Coil
Recommended Drive Condition
Unipolar Drive, 1-2 Phase Excitation.

1(Red) - 3(Blue)	Coil resistance ≈ 46.0Ω (20 °C)
1(Red) - 4(Orange)	
1(Red) - 5(Yellow)	
1(Red) - 6(White)	

8-3. Models: AOYG30KATA, AOYG36KATA, AOYG45KATA, and AOYG54KATA

INVERTER ASSEMBLY

30 model : EZ-0190DHUE 45 model : EZ-0192HUE
 36 model : EZ-0190DHUE 54 model : EZ-01907HUE

P700 Thermistor Characteristics.

Thermistor	Temperature	0 °C	20 °C	30 °C
Thermistor (Heatsink temp.)		0.33 k Ω	0.12 k Ω	0.08 k Ω
		4.10 V	4.62 V	4.75 V

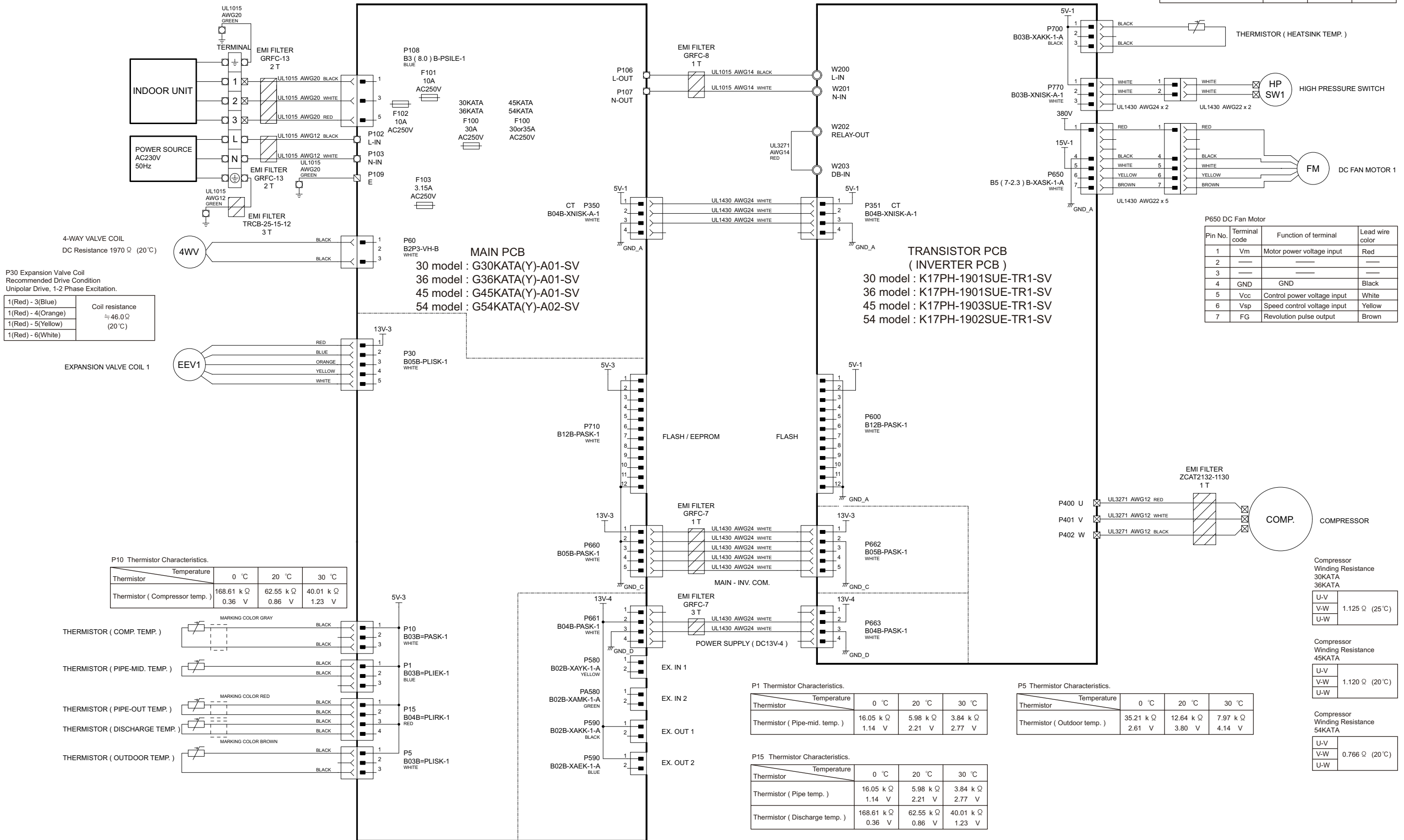

P10 Thermistor Characteristics.

Thermistor	Temperature	0 °C	20 °C	30 °C
Thermistor (Compressor temp.)		168.61 k Ω	62.55 k Ω	40.01 k Ω
		0.36 V	0.86 V	1.23 V

P1 Thermistor Characteristics.

Thermistor	Temperature	0 °C	20 °C	30 °C
Thermistor (Pipe-mid. temp.)		16.05 k Ω	5.98 k Ω	3.84 k Ω
		1.14 V	2.21 V	2.77 V

P5 Thermistor Characteristics.

Thermistor	Temperature	0 °C	20 °C	30 °C
Thermistor (Outdoor temp.)		35.21 k Ω	12.64 k Ω	7.97 k Ω
		2.61 V	3.80 V	4.14 V

P15 Thermistor Characteristics.

Thermistor	Temperature	0 °C	20 °C	30 °C
Thermistor (Pipe temp.)		16.05 k Ω	5.98 k Ω	3.84 k Ω
		1.14 V	2.21 V	2.77 V
Thermistor (Discharge temp.)		168.61 k Ω	62.55 k Ω	40.01 k Ω
		0.36 V	0.86 V	1.23 V

TECHNICAL DATA AND PARTS LIST

TECHNICAL DATA AND PARTS LIST