

FUJII ELECTRIC

SPLIT TYPE
AIR CONDITIONER

CASSETTE type (50Hz)

SERVICE MANUAL

Models	Indoor unit	Outdoor unit
	RCW-18CA	RO-18CB
	RCW-18HA	RO-18HB

C O N T E N T S

SPECIFICATIONS	1
OUTLINE AND DIMENSIONS	3
CIRCUIT DIAGRAM	5
REFRIGERANT SYSTEM DIAGRAM	7
ERROR CONTENTS	8
INDOOR PRINTED CIRCUIT BOARD CIRCUIT DIAGRAM	9
DISASSEMBLY ILLUSTRATION	10
PARTS LIST	18

S P E C I F I C A T I O N S

TYPE		COOL	COOL & HEAT
INDOOR UNIT		RCW-18CA	RCW-18HA
OUTDOOR UNIT		RO-18CB	RO-18HB
COOLING CAPACITY	(kW)	4.95 - 5.10	4.85 - 5.00
HEATING CAPACITY	(kW)	—	5.30 - 5.45

ELECTRICAL DATA

POWER SOURCE	(V)	220 - 240	
FREQUENCY	(Hz)	50	
RUNNING CURRENT	(A)	COOLING	8.5 - 8.0
		HEATING	—
INPUT WATTS	(kW)	COOLING	1.80 - 1.90
		HEATING	—
E.E.R.	(kW/kW)	COOLING	2.55 - 2.68
		HEATING	—
STARTING CURRENT	(A)	42	
MOISTURE REMOVAL	(ℓ/h)	2.1	
AIR CIRCULATION-Hi	(m³/hr)	650	

COMPRESSOR

TYPE	Hermetic type, Rotary		
DISCRIMINATION	2JS318D5BA02		
POWER SOURCE	220 - 240V 50Hz		
REFRIGERANT	R-22	(g)	1,150
			1,500

FAN MOTOR

POWER SOURCE	(V)	240	
INDOOR UNIT	DISCRIMINATION	MFA-18GTT	MFA-18GTBT
	HI-SPEED	(r.p.m.)	820
	MED-SPEED	(r.p.m.)	740
	LO-SPEED	(r.p.m.)	620
OUTDOOR UNIT	DISCRIMINATION	MFB-24JTBT	
	FAN SPEED	(r.p.m.)	Hi : 800 Lo : 400

DIMENSIONS

INDOOR UNIT	H x W x D (mm)	235 x 580 x 580 +70	
OUTDOOR UNIT		650 x 830 x 320	
GRILLE		35 x 650 x 650	

WEIGHT

INDOOR UNIT	GROSS / NET (kg)	23 / 18	
OUTDOOR UNIT		55 / 51	60 / 56
GRILLE		4.3 / 2.2	

MODELS				RCW-18CA	RCW-18HA
				RO-18CB	RO-18HB
REFRIGERANT CIRCUIT	DISCHARGE PRESSURE	kg/cm ² G	COOLING	21.0	22.0
			HEATING	—	—
	SUCTION PRESSURE	kg/cm ² G	COOLING	5.5	4.6
			HEATING	—	—
	DISCHARGE TEMP.	°C	COOLING	73	81
			HEATING	—	—
	REFRIG. PIPE LENGTH			7.5	
	DISCHARGE AIR TEMP.	°C	COOLING	13	
HEATING			—	—	
CONDITION	INDOOR ENTERING AIR TEMP.	DB/WB °C	COOLING	27.0 / 19.0	
			HEATING	20.0 / —	
	OUTDOOR ENTERING AIR TEMP.	DB/WB °C	COOLING	35.0 / 24.0	
			HEATING	7.0 / 6.0	
PIPING	PIPE DIA. SIZE	LIQUID	6.35		
		GAS	12.7		
	CONNECTION METHOD			Flare	
	BETWEEN	HEIGHT	m	Max. 8	
		PIPE LENGTH		Max. 20	
REFRIGERANT TYPE				R-22	

REFRIGERANT CHARGE (R-22)

MODELS		PIPE LENGTH				Additional refrigerant
		7.5 m	10 m	15 m	20 m	
FULL CHARGE AMOUNT	RCW-18CA	1,150 g	1,188 g	1,263 g	1,338 g	15 g / m
	RCW-18HA	1,500 g	1,575 g	1,725 g	1,875 g	30 g / m

OUTLINE AND DIMENSIONS

INDOOR UNIT

(unit : mm)

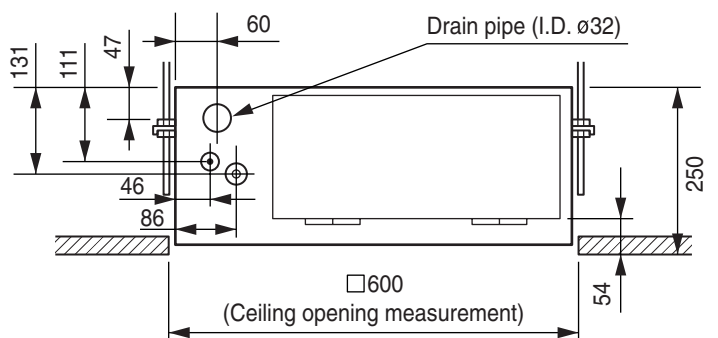
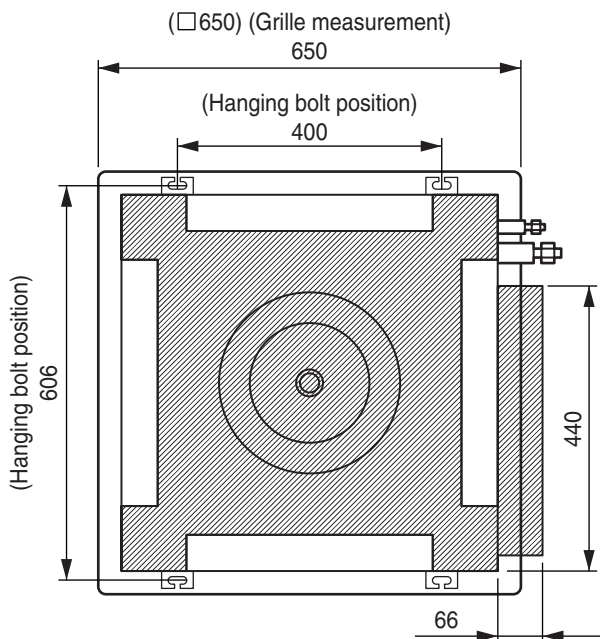
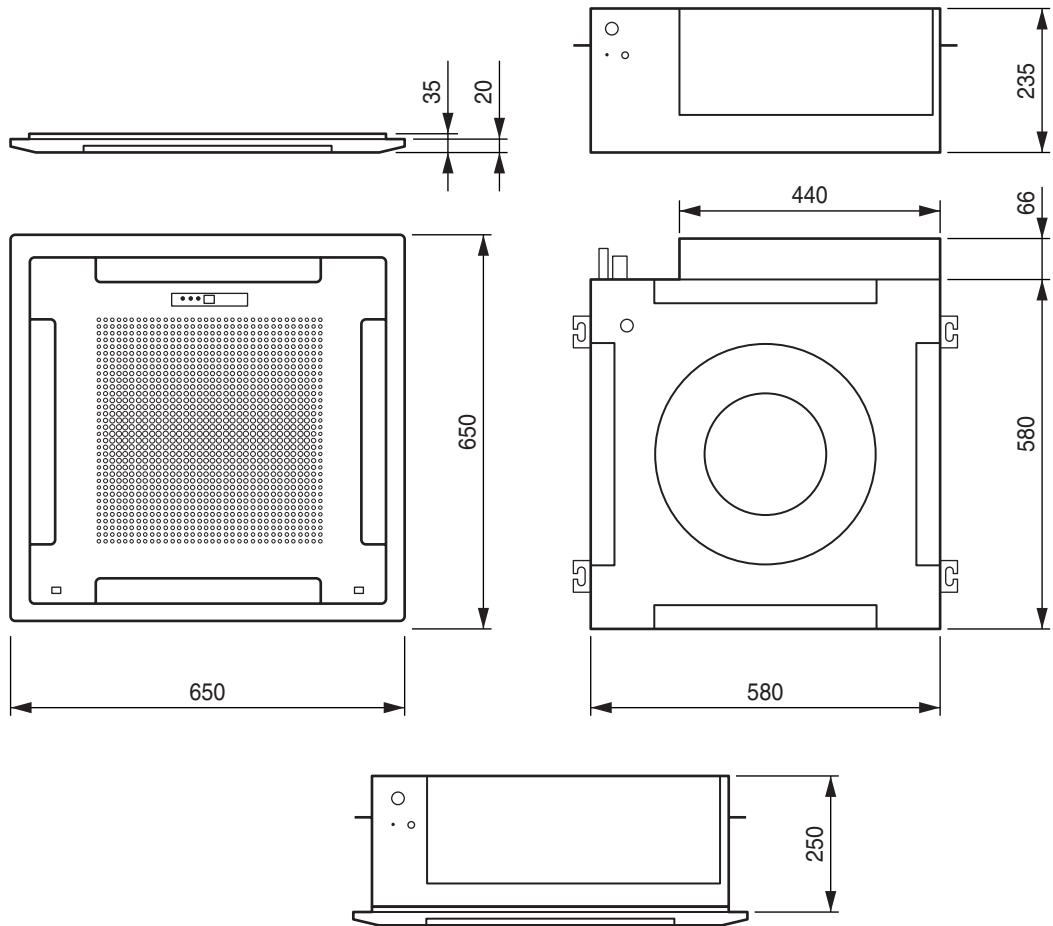

OUTDOOR UNIT

(unit : mm)

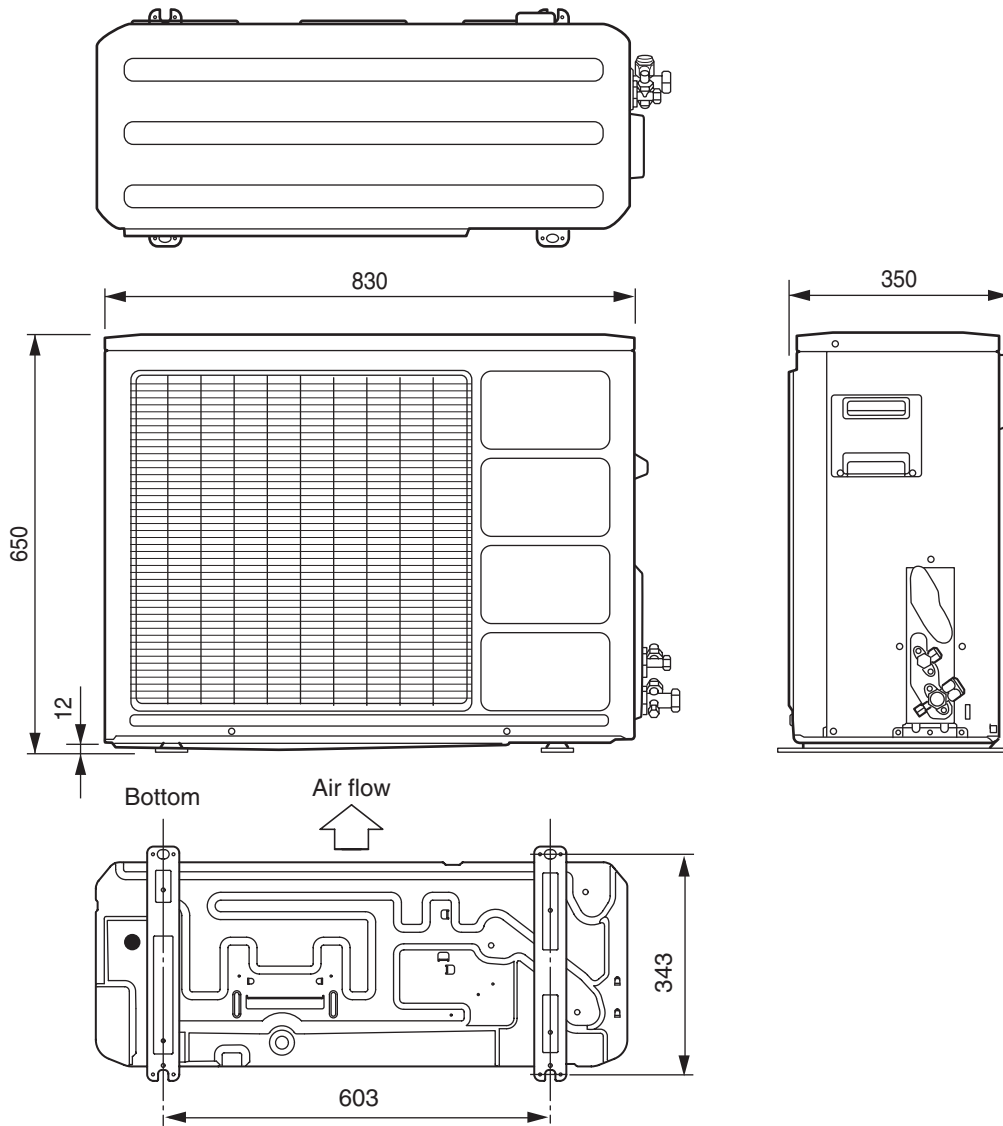

CIRCUIT DIAGRAM

Models : RCW-18CA / RO-18CB

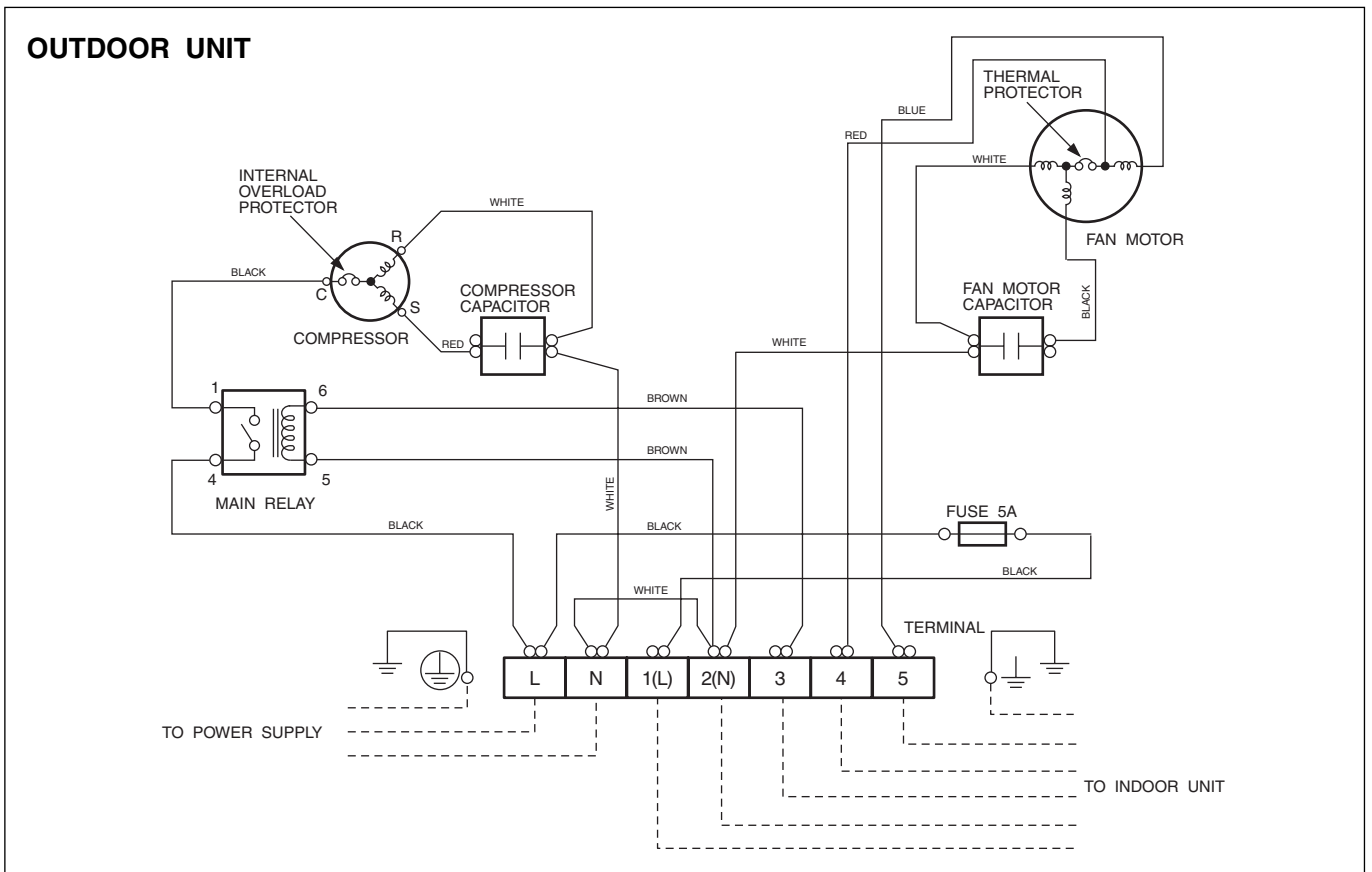
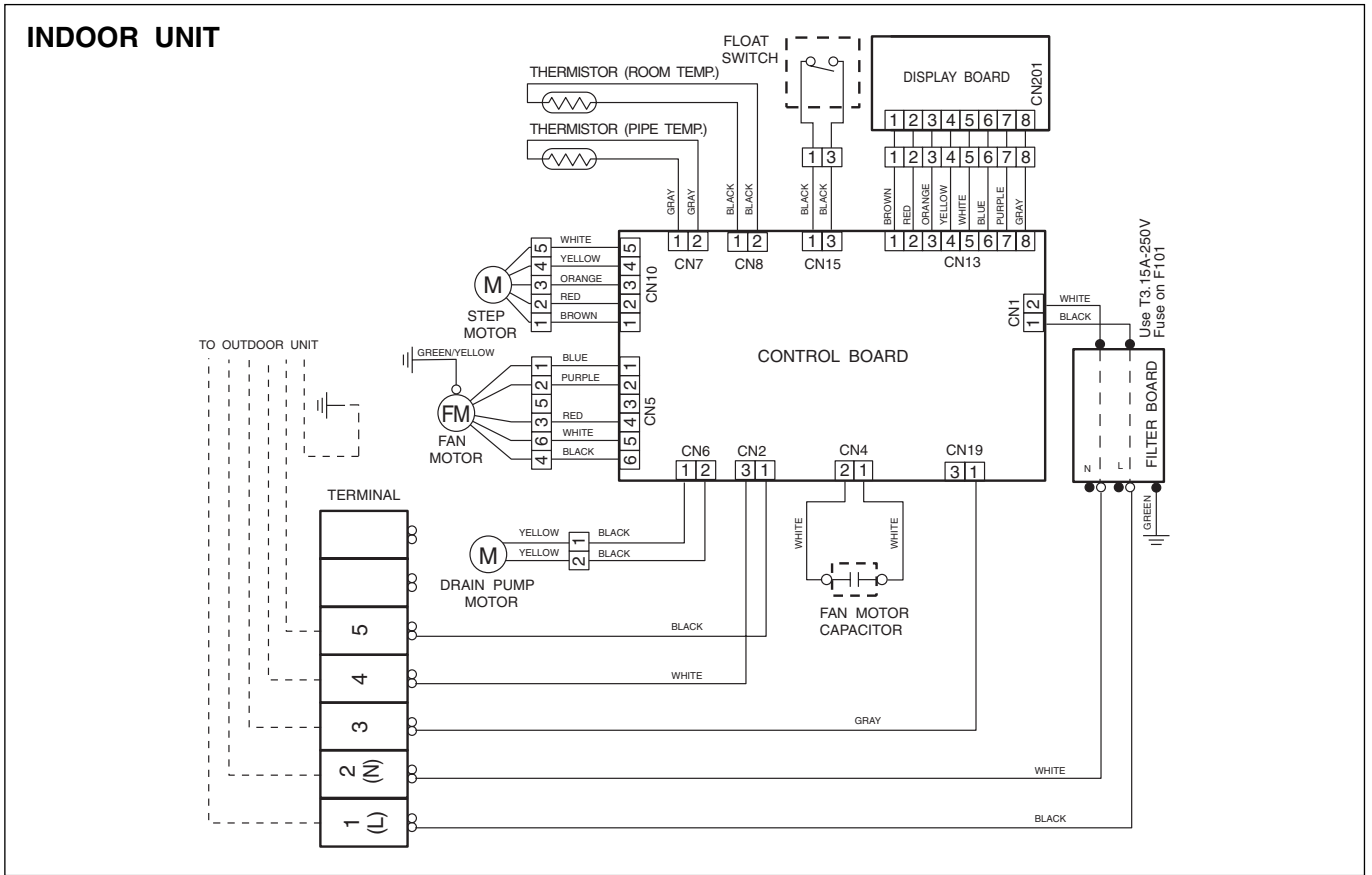

Models : RCW-18HA / RO-18HB

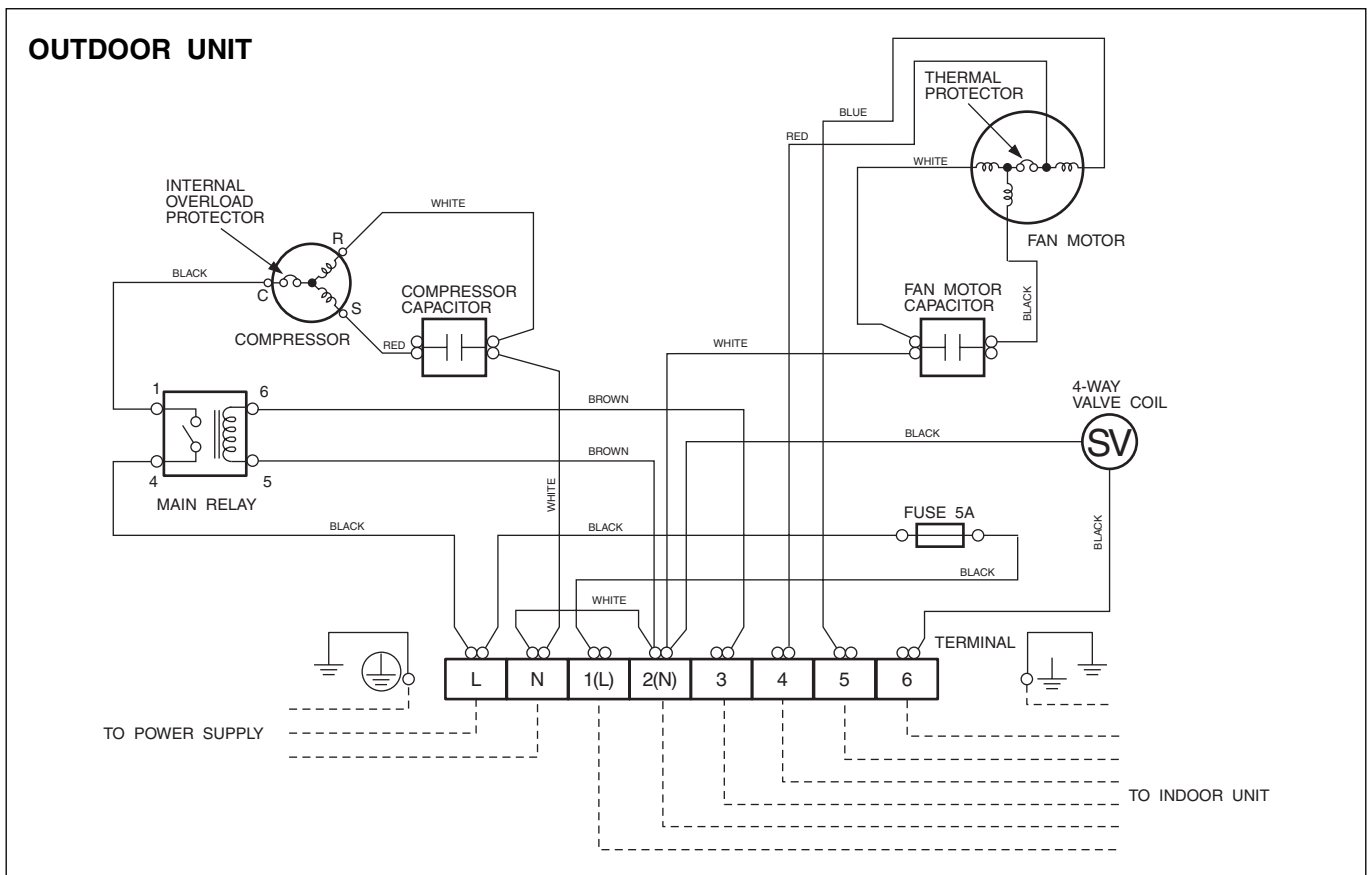
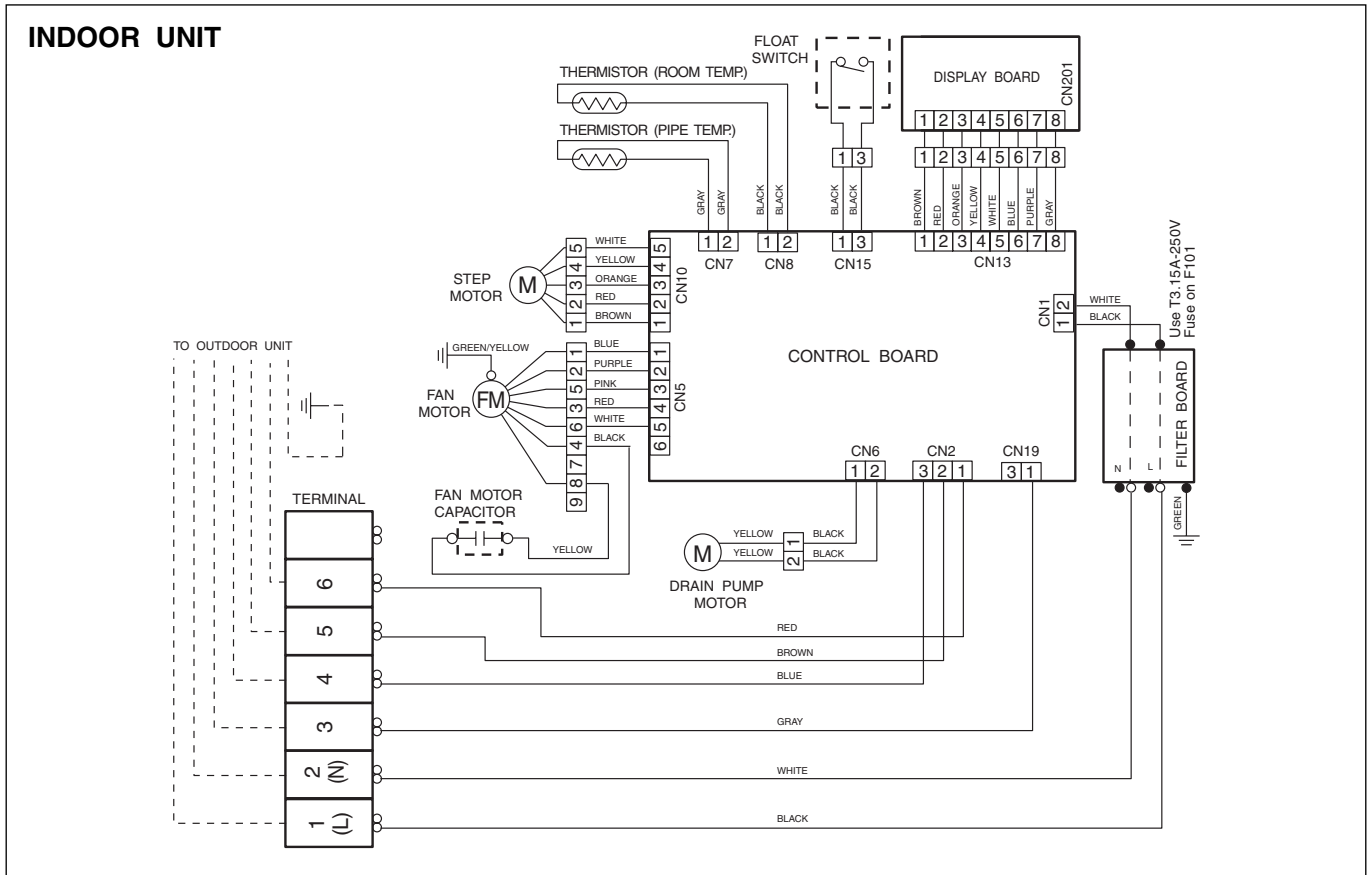

REFRIGERANT SYSTEM DIAGRAM

Models : RCW-18CA / RO-18CB

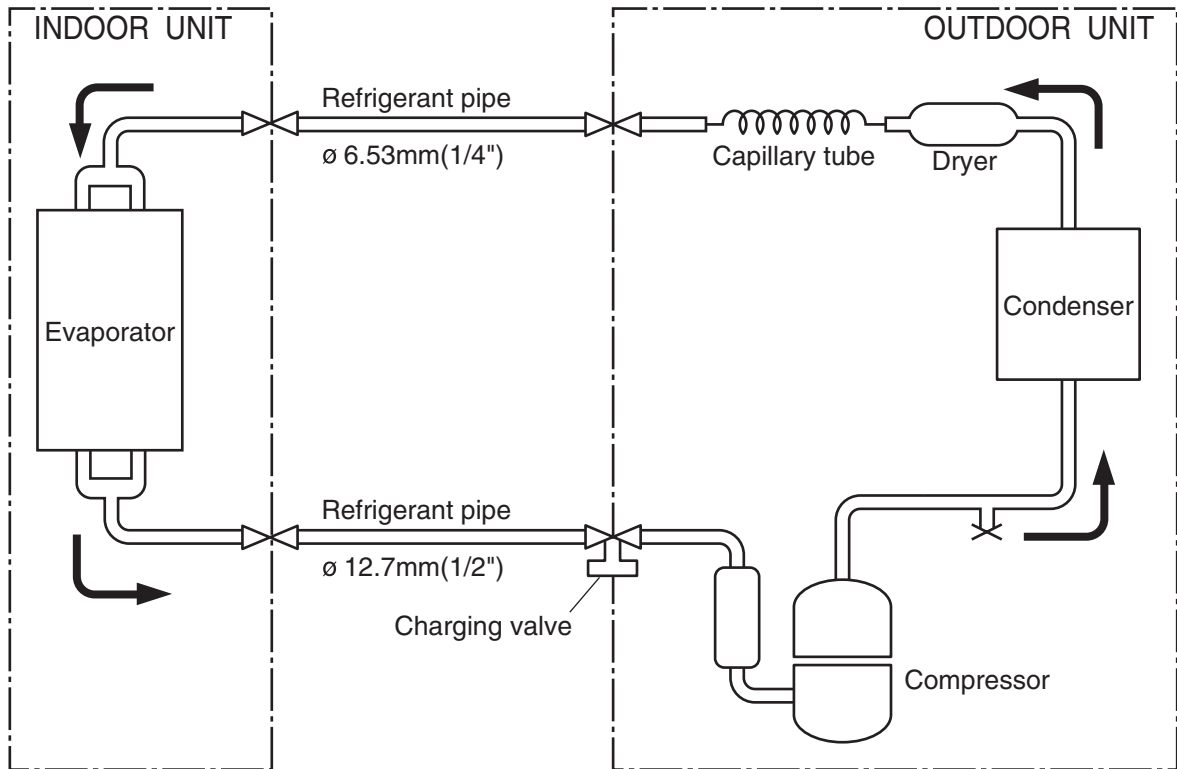

Models : RCW-18HA / RO-18HB

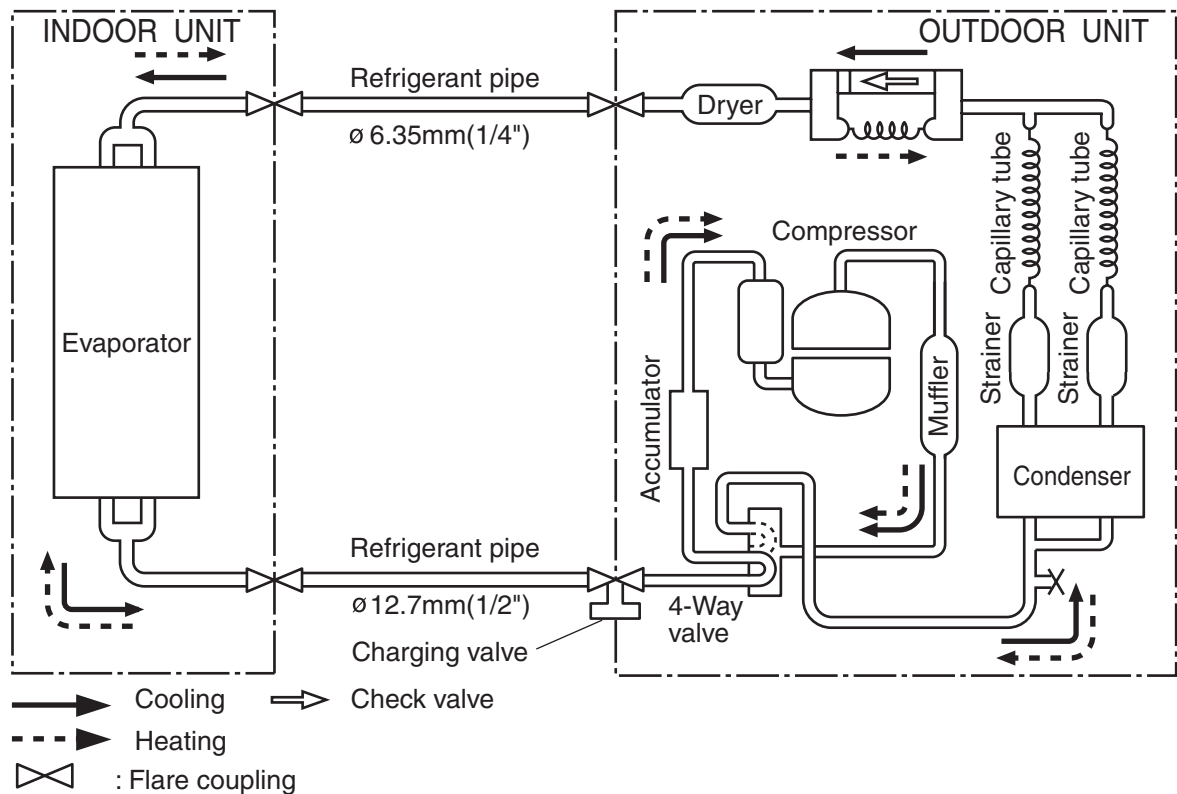

ERROR CONTENTS

Operation can be checked by lighting and flashing of the grille display section OPERATION and TIMER lamps.

Perform judgment in accordance with the following.

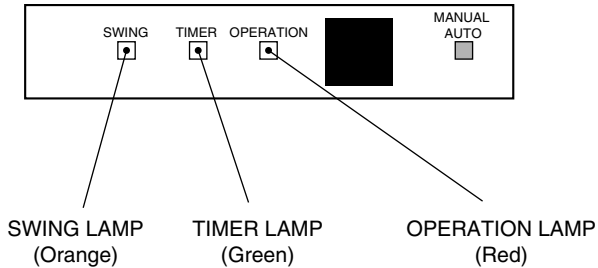

TEST RUNNING

When the air conditioner is run by pressing the remote control unit test run button, the OPERATION and TIMER lamps flash slowly at the same time.

ERROR

The OPERATION, TIMER, and SWING lamps operate as follows (Table 1) according to the error contents.

Table 1

Error display			Error contents
OPERATION lamp	TIMER lamp	SWING lamp	
Blinks	Blinks	Goes off	Model information abnormal (permanent type)
Pulses 4 times	Blinks	Goes off	Drain abnormal (permanent type)
Pulses 6 times	Blinks	Goes off	Indoor fan abnormal
Pulses 2 times	Blinks	Goes off	Room air temperature thermistor open circuit
		Blinks	Room air temperature thermistor short circuit
Pulses 3 times	Blinks	Goes off	Piping thermistor open circuit
		Blinks	Piping thermistor short circuit

CHECK ITEMS

1. INDOOR UNIT

- (1) Is operation of each button on the remote control unit normal?
- (2) Does each lamp light normally?
- (3) Do not air flow direction louvers operate normally?
- (4) Is the drain normal?
- (5) Is there any abnormal noise and vibration during operation?

2. OUTDOOR UNIT

- (1) Is there any abnormal noise and vibration during operation?
 - (2) Will noise, wind or drain water from the unit disturb the neighbors?
 - (3) Is there any gas leakage?
- Do not operate the air conditioner in the test running state for a long time.

INDOOR PRINTED CIRCUIT BOARD CIRCUIT DIAGRAM

Model : RCW-18CA

CONTROLLER PCB ASSEMBLY (MAIN PCB) EZ-003SWSE-C

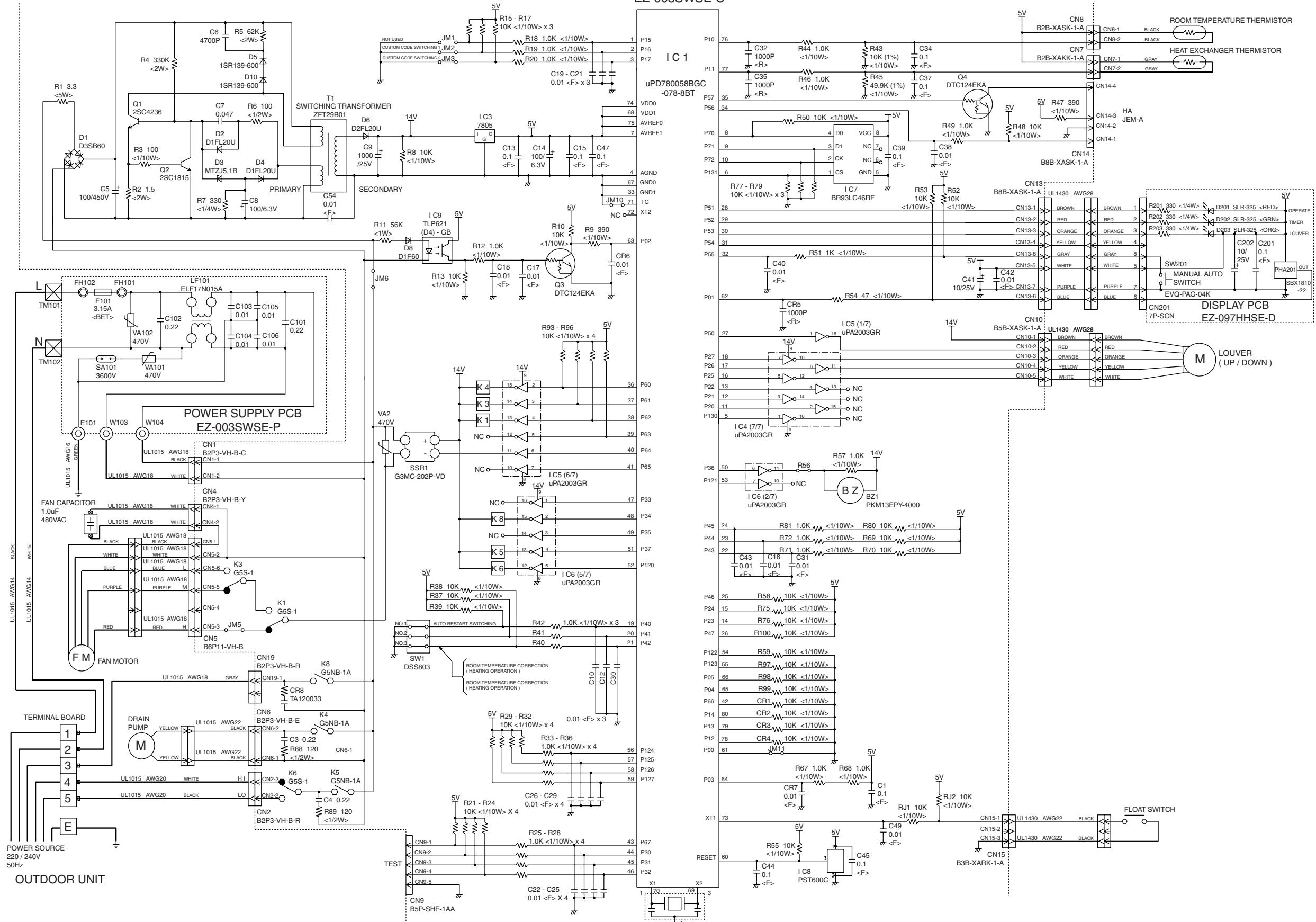

DISASSEMBLY ILLUSTRATION

Models : RCW-18CA
RCW-18HA

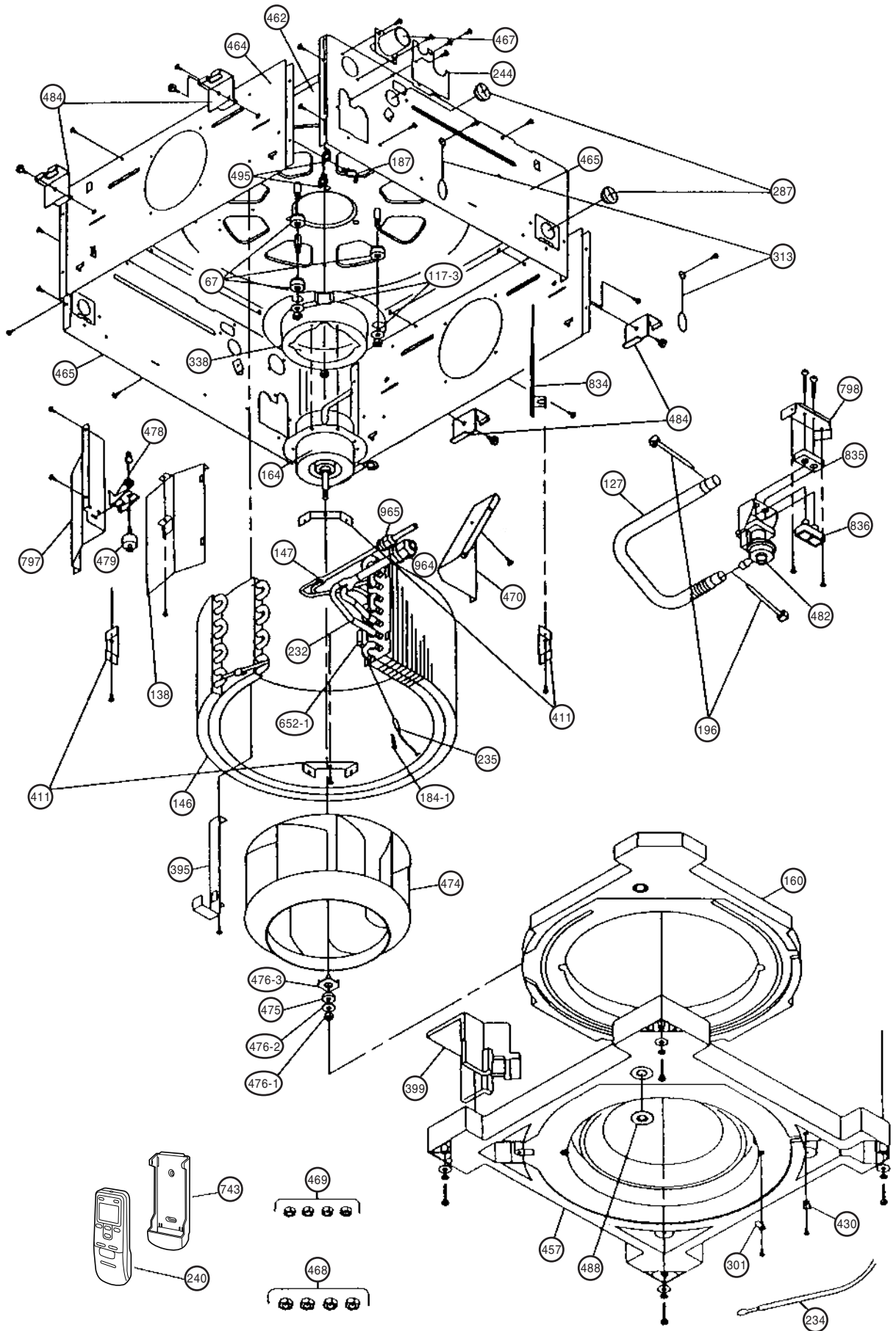

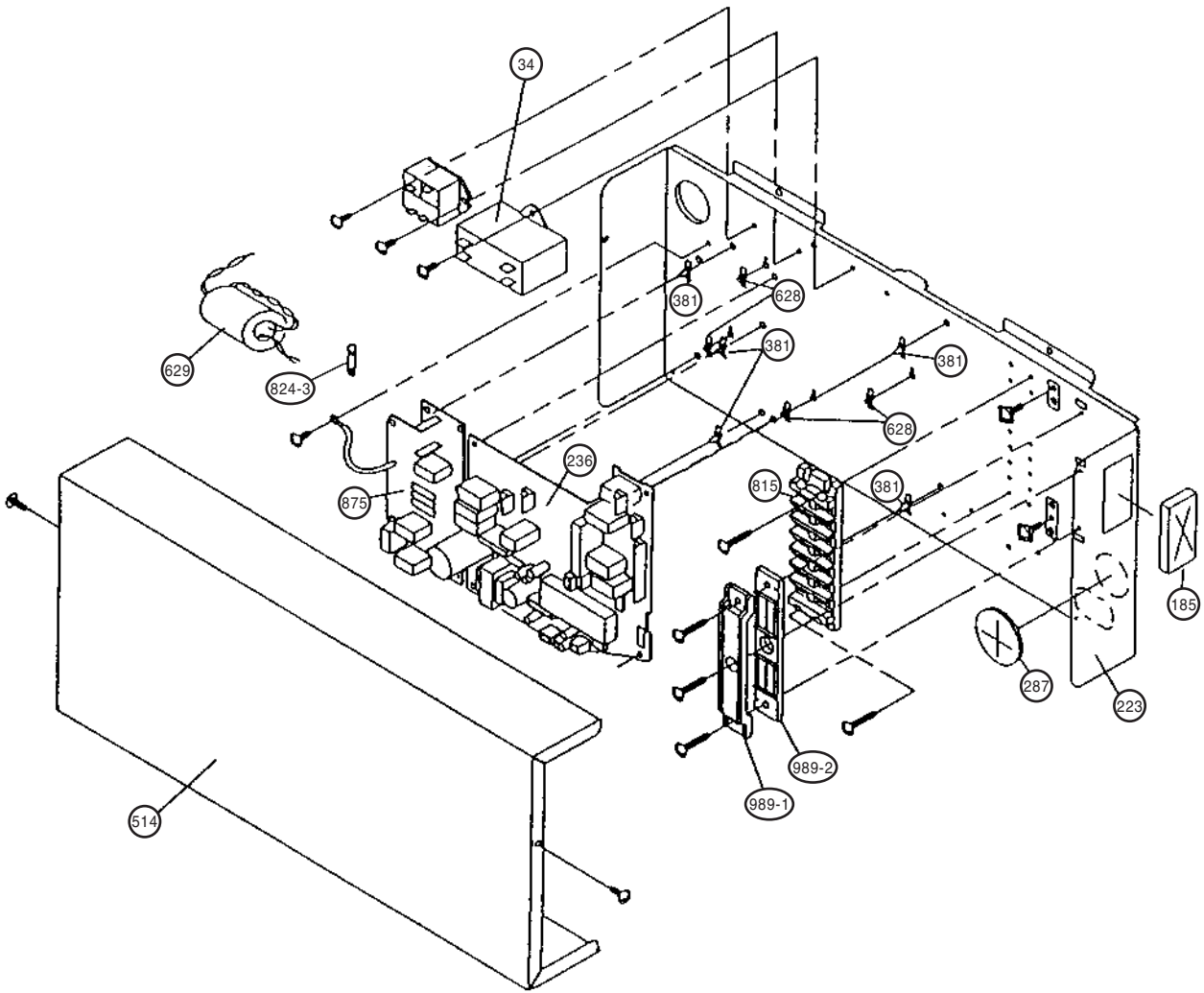

Model : CG-E

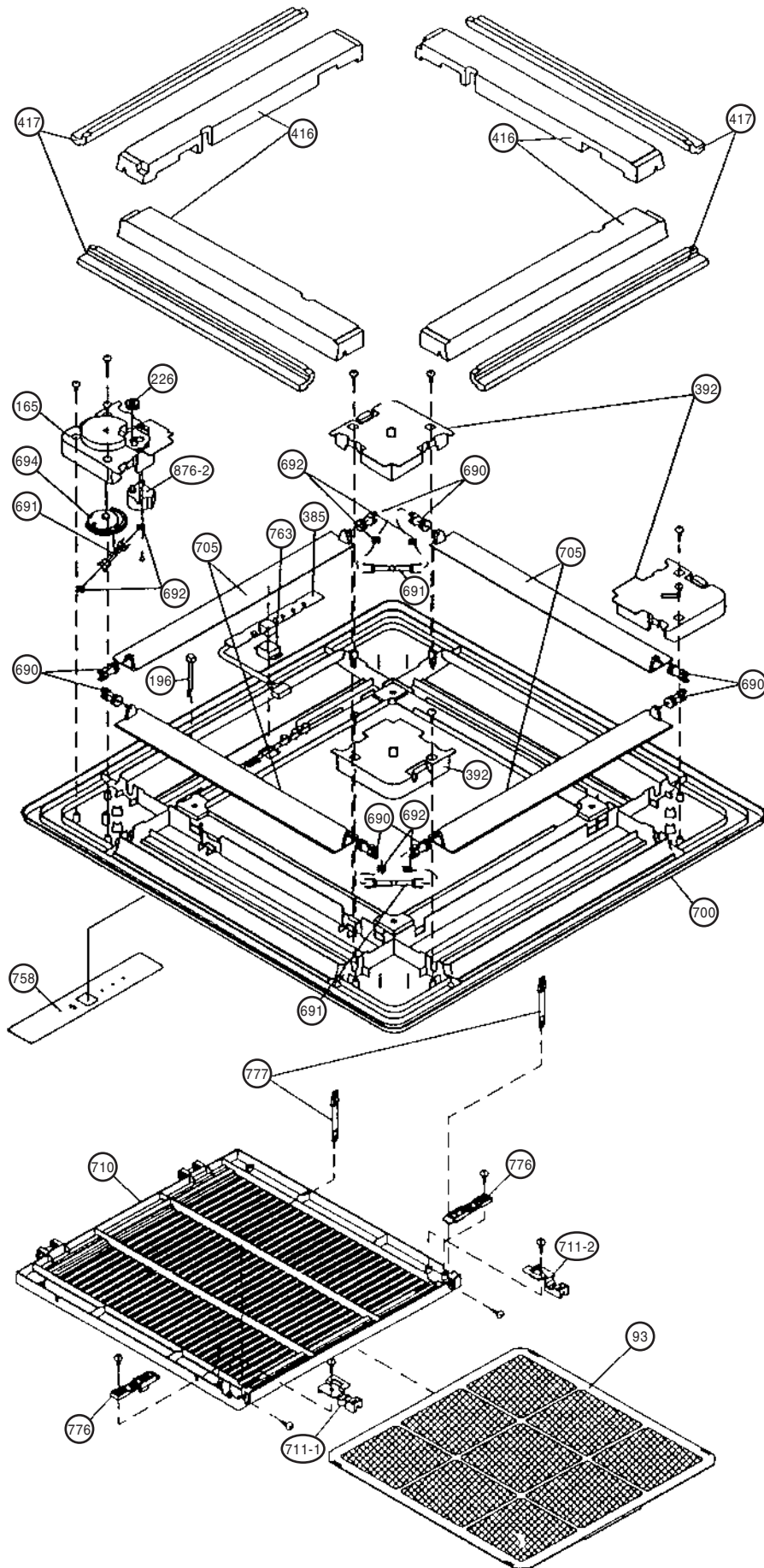

Models : RO-18CB
RO-18HB

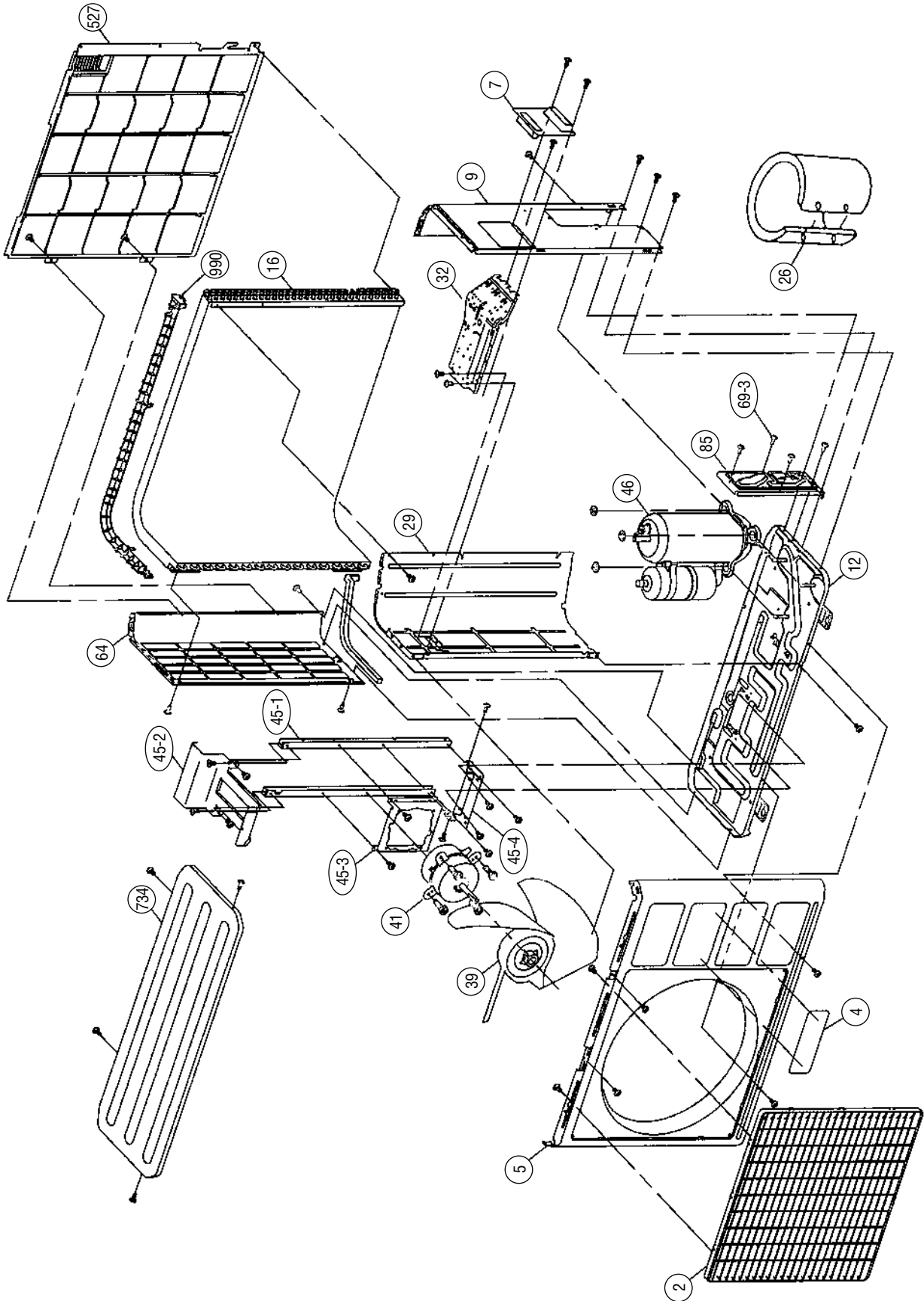

Model : RO-18CB

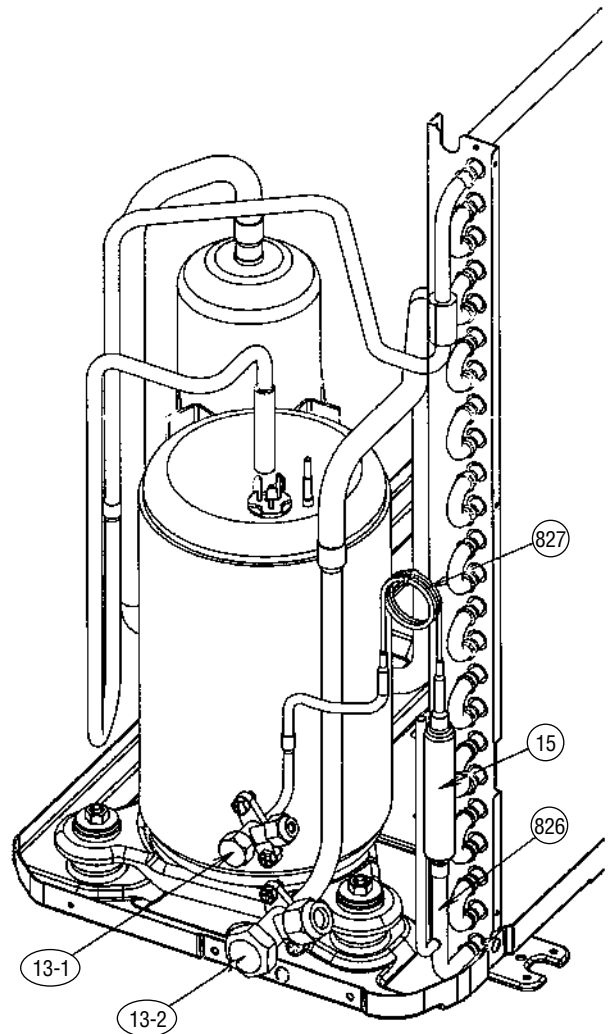
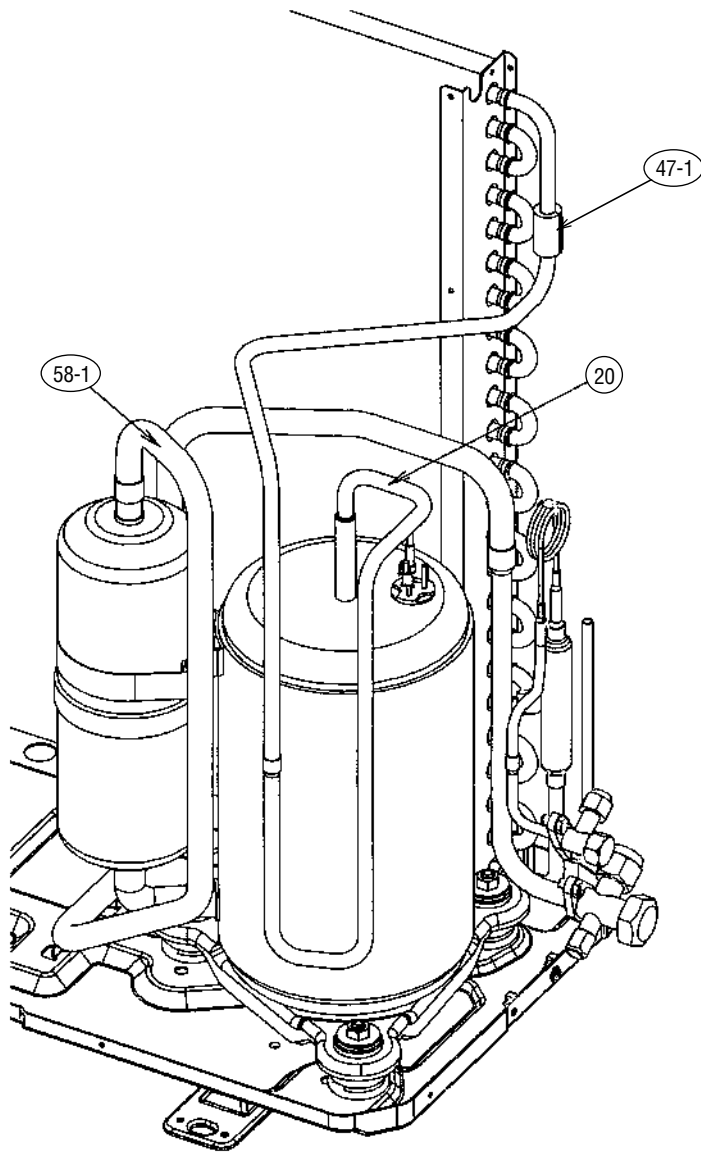

Model : RO-18HB

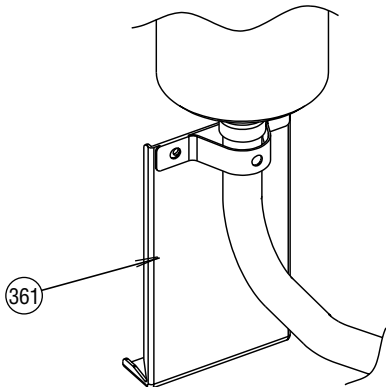
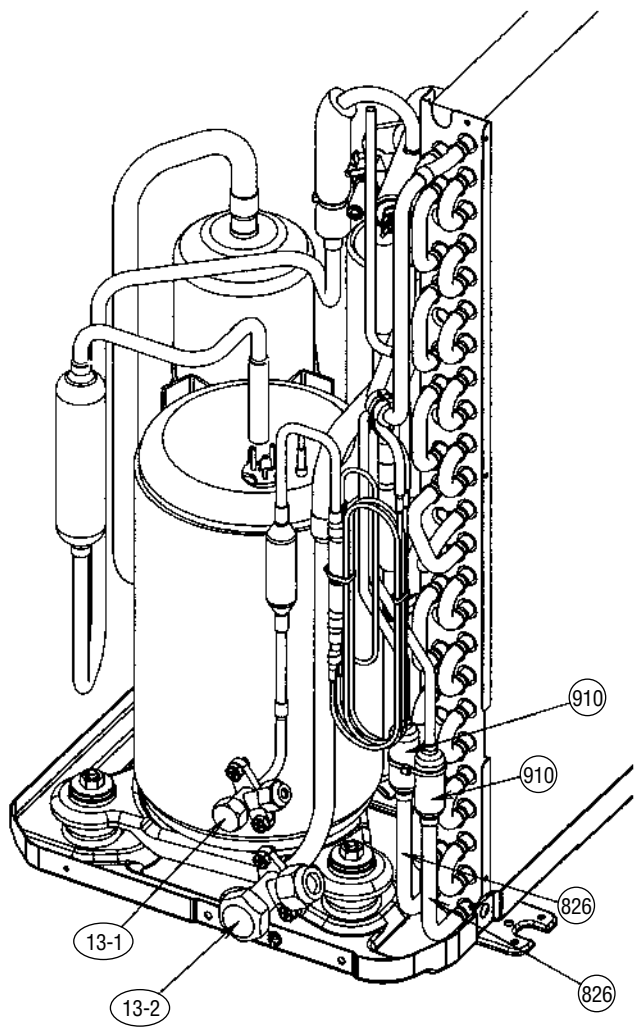
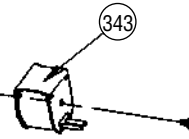
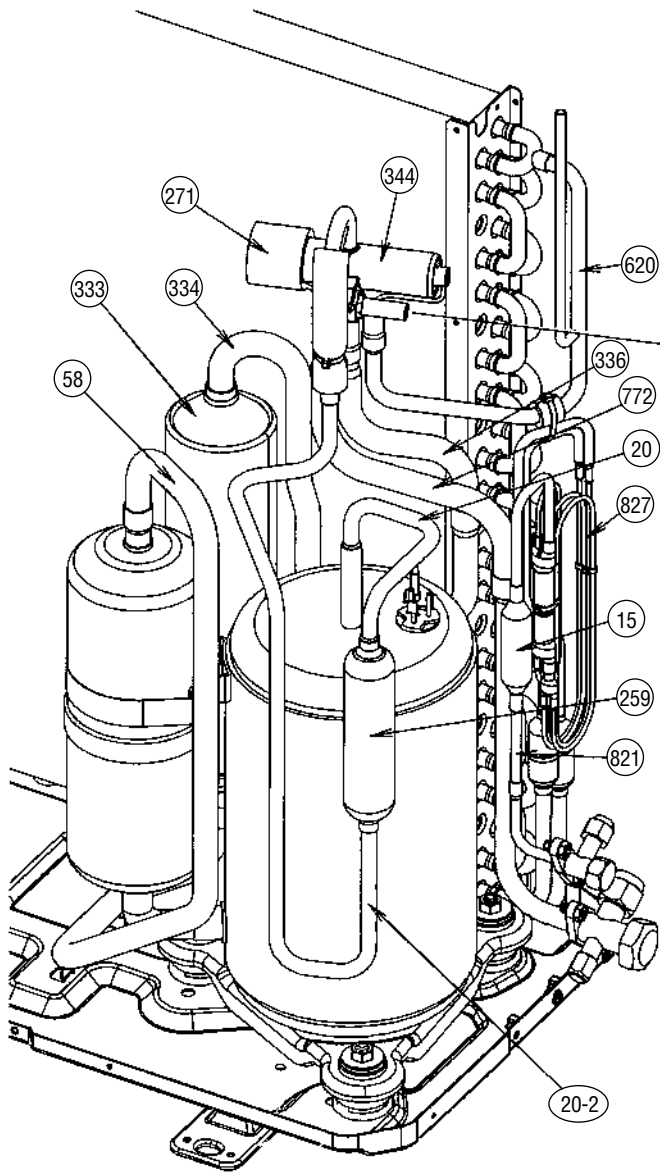

Model : RO-18CB

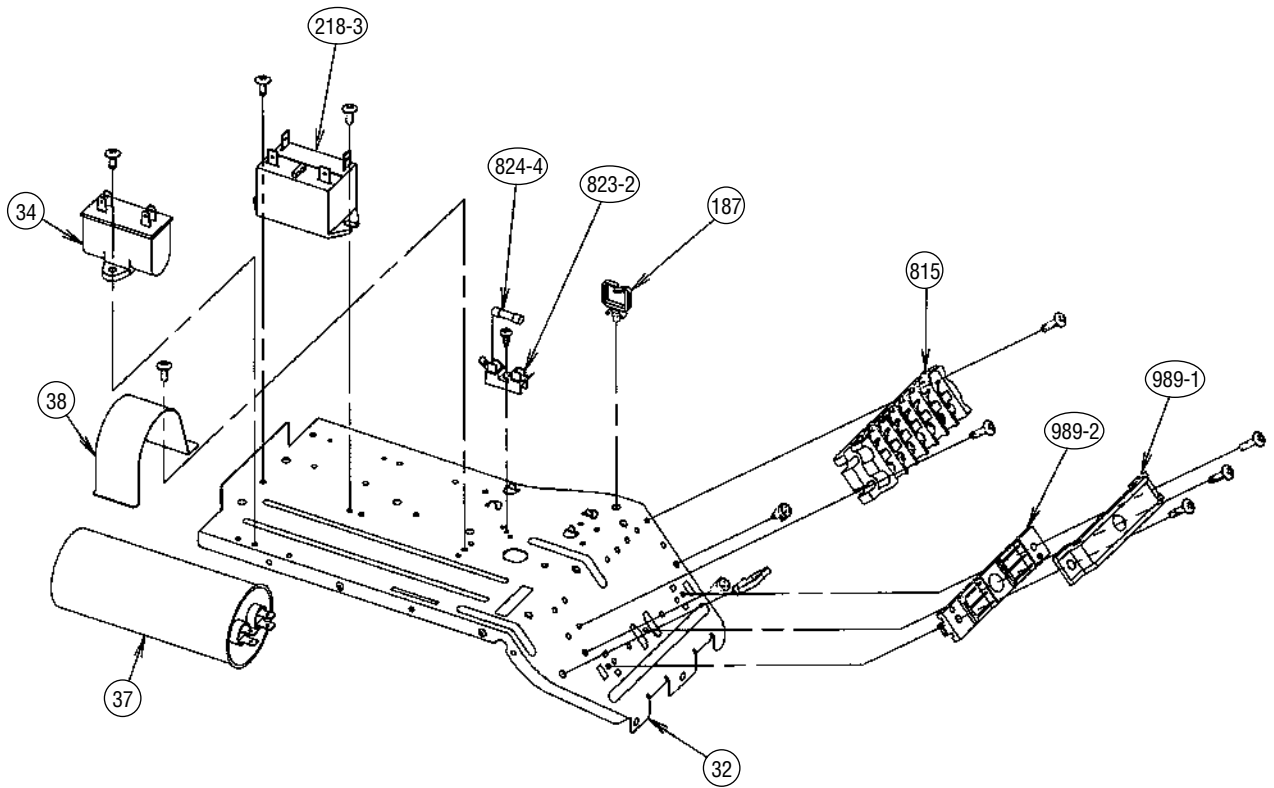

Model : RO-18HB

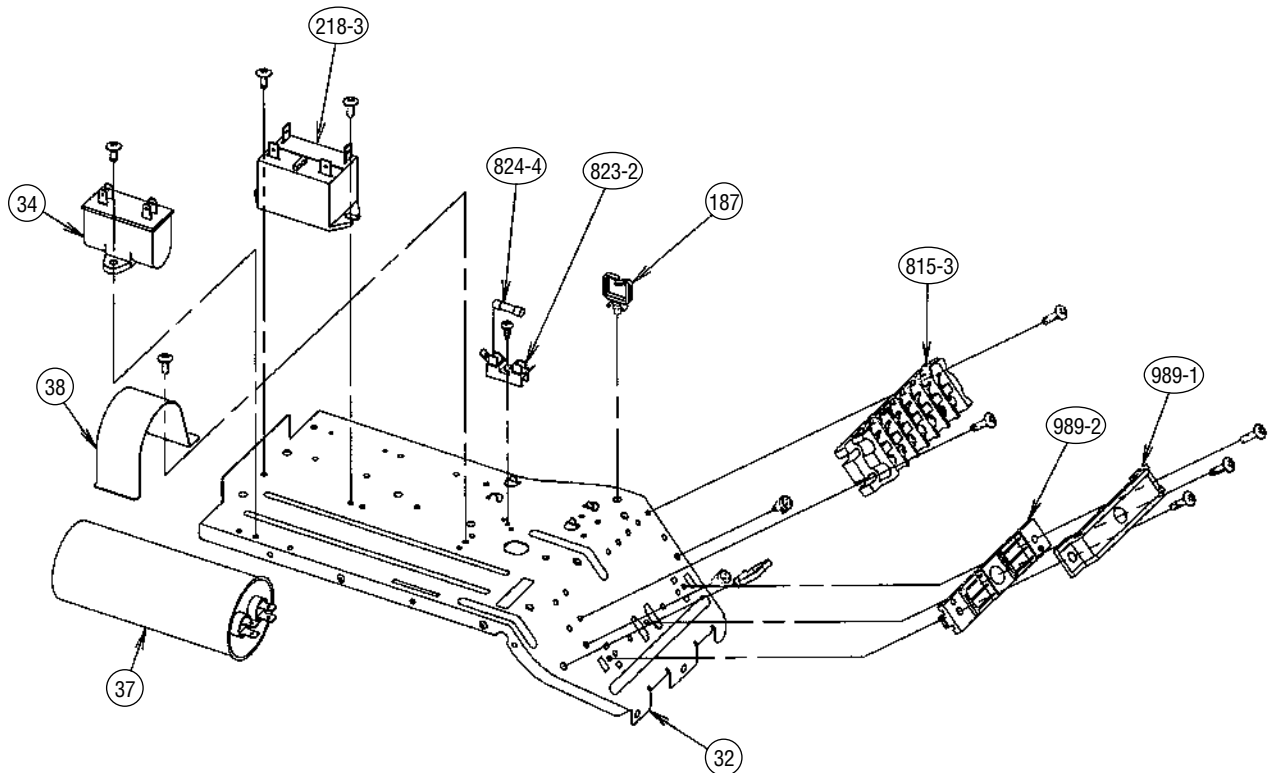

Models : RO-18CB
RO-18HB

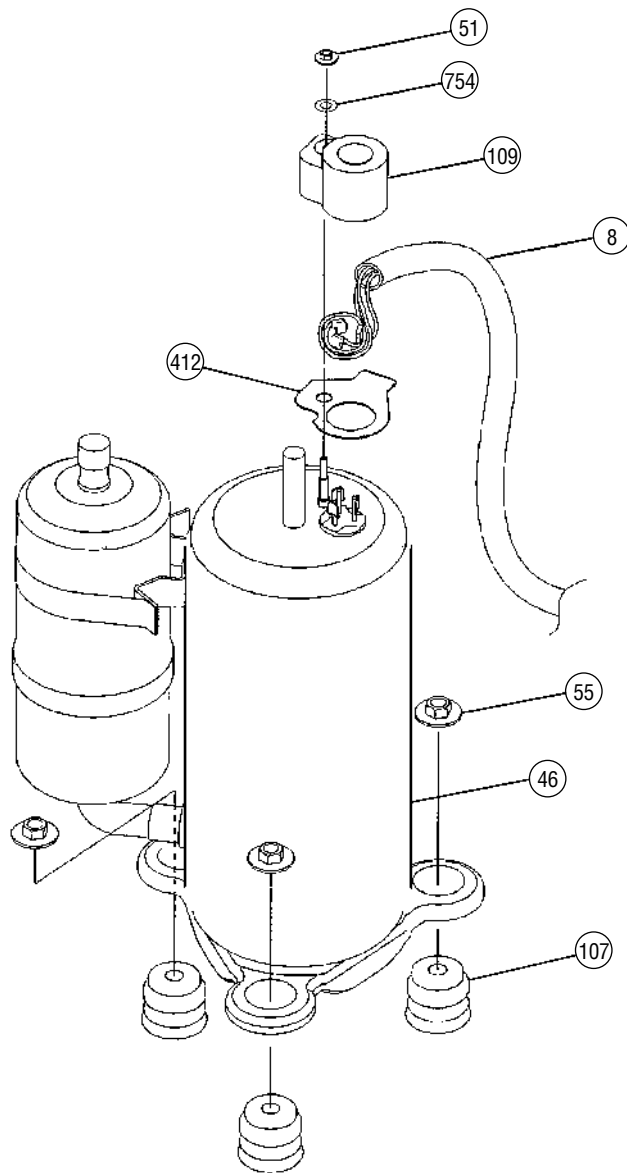

PARTS LIST

INDOOR UNIT

When you order parts, please make a photocopy of this page and fill the number of the parts in the "Order" column.

Ref. No.	Description	Part No.		Ord. Q'ty	Ref. No.	Description	Part No.		Ord. Q'ty
		RCW-18CA	RCW-18HA				RCW-18CA	RCW-18HA	
34	Capacitor (Fan Motor)	9704305046	9703306044		467	Drain Port	313005415658	313005415658	
67	Rubber	9361279001	9361279001		468	Special Nut-A (Large)	313005446653	313005446653	
117-3	Special Washer M6	313306391007	313306391007		469	Special Nut-B (Small)	313005446759	313005446759	
127	Drain Hose	9359659013	9359659013		470	Separate Wall-B	9359648000	9359648000	
138	Separate Wall-A	9359647003	9359647003		474	Turbo Fan	9359658009	9359658009	
146	Evaporator Assy-IN	9363516005	9363516005		475	Turbo Fan Rubber	9366013006	9366013006	
147	Inlet Pipe (Eva.) Assy	9363517002	9363517002		476-1	Special Nut M8	313005360755	313005360755	
160	Drain Pan	9359651000	9359651000		476-2	Special Washer	301801185049	301801185049	
164	Fan Motor Assy-IN	9601040026	9601040057		476-3	Special Washer	9359954002	9359954002	
184-1	Thermo. Spring-A	313728262708	313728262708		478	Sensor M. Bracket	9359654001	9359654001	
185	Rubber Bushing	313005066051	313005066051		479	Float Switch	313005416154	313005416154	
187	Clamp No. 1219	313361271706	313361271706		482	Pump Unit	9359974000	9359974000	
196	Clamp SKB-150	313035356905	313035356905		484	Hanger Metal	9359644002	9359644002	
223	Control Box	9359661016	9359661016		488	Drain Pan Plug	9359653004	9359653004	
232	Outlet Pipe (Eva.) Assy	9363518009	9363518009		495	Clamp No. 2U46	9352715006	9352715006	
234	Thermistor Assy-Room	9703299032	9703299032		514	Control Box Cover	9359662006	9359662006	
235	Thermistor Assy-Pipe	9703297014	9703297014		628	Locking Spacer-B	313005446558	313005446558	
236	Controller PCB Assy	9704557490	9704557506		629	EMI Filter	0400197119	0400197119	
240	Remote Control Unit	9371190044	9371190037		652-1	Therm. Holder Pipe	313806262805	313806262805	
244	Pipe Cover	9359646006	9359646006		743	Remote Control Holder Case	9371190044	9371190037	
287	Cap (Power)	9352173011	9352173011		797	Separate Wall-C	9359649007	9359649007	
301	Clamp NK-2N	313985355201	313985355201		798	Pump Hook Bracket	9359650003	9359650003	
313	Hooking Wire	9359983002	9359983002		815	Terminal-7P	9358660102	9358660102	
338	Motor Fixture	9359656005	9359656005		824-3	Fuse	0600222512	0600222512	
381	Locking Spacer	313209391506	313209391506		834	Wire Cover	9359878001	9359878001	
395	Supporter (Eva.)	9359669005	9359669005		835	Cushion-A (For Pump)	9352211013	9352211013	
399	Air Duct	9359660002	9359660002		836	Cushion-B (For Pump)	9356084016	9356084016	
411	Supporter-A	9359655008	9359655008		875	Filter PCB Assy	9704561169	9704561169	
430	Clamp NK-7N	313095365602	313095365602		964	Flare Nut-A	313996239804	313996239804	
457	Drain Pan Support	9359652007	9359652007		965	Flare Nut-B	9351062019	9351062019	
462	Top Cover Plate	9359642015	9359642015		989-1	Cord Clamp-A	9359822011	9359822011	
464	Body-A	9359643005	9359643005		989-2	Cord Clamp-B	9359823018	9359823018	
465	Body-B	9359645009	9359645009						

GRILLE ASSY (CG-E)

Ref. No.	Description	Part No.	Ord. Q'ty	Ref. No.	Description	Part No.	Ord. Q'ty
93	Filter	9359632009		694	Cam Gear	9359628002	
165	Motor Cover	9359623014		700	Panel	9359619017	
196	Clamp SKB-150	313035356905		705	Louver	9359624011	
226	Motor Gear	9359629009		710	Intake Grille	9360543011	
385	Indicator PCB Assy	9702224011		711-1	Filter Clamp-A	9359634003	
392	Cover-A	9359622017		711-2	Filter Clamp-B	9359635000	
416	Insulation (Panel)-A	9359620006		758	Decoration Plate	9360862013	
417	Insulation (Panel)-B	9359621003		763	Receiver Cover	9359630005	
690	Joint-A	9359626008		776	Grille Stopper	9359633013	
691	Joint-B	9359627005		777	Grille Hook	9359761006	
692	Joint Shaft	9359625001		876-2	Step Motor-V	9360307019	





OUTDOOR UNIT

When you order parts, please make a photocopy of this page and fill the number of the parts in the "Order" column.

Ref. No.	Description	Part No.		Ord. Q'ty	Ref. No.	Description	Part No.		Ord. Q'ty
		RO-18CB	RO-18HB				RO-18CB	RO-18HB	
2	Fan Guard	9371187013	9371187013		69-3	Bolt, Hex. Socket	301210060360	301210060360	
4	Emblem-Rear	9361328006	9361328006		85	Valve Plate Ptd	9371928012	9371928012	
5	Front Panel Ptd	9371924014	9371924014		107	Rubber Seat-A	9351049010	9351049010	
7	Connector Cover (Cabinet)	9366398004	9366398004		109	Terminal Cover (Comp)	9351048013	9351048013	
8	Wire Assy (Comp)	9372334010	9372334010		187	Clip (Cable)	9352715006	9352715006	
9	Side Panel R Ptd	9371927015	9371927015		218-3	Relay	9900074012	9900074012	
12	Base Assy Ptd	9371920016	9371920016		259	Muffler	—	9372369012	
13-1	3-Way Valve	9372648018	9372648018		271	4-Way Valve Rubber	—	313728251908	
13-2	2-Way Valve	9372647011	9372647011		333	Accumulator	—	9368391003	
15	Dryer	9368111014	9368112011		334	Suction Pipe-B	—	9372175093	
16	Condenser Assy	9372181065	9372181089		336	Suction Pipe-C	—	9372177013	
20	Discharge Pipe Assy	9371581064	—		343	Solenoid	—	9900165017	
20	Discharge Pipe-A	—	9372179017		344	4-Way Valve	—	9970036019	
20-2	Discharge Pipe-B	—	9372180013		361	Accum. Support Assy	—	9372252017	
26	Compressor Cover-A	9372327012	9372327012		412	Cvr Gasket (Comp)	9351051013	9351051013	
29	Separate Wall	9371933016	9371933016		527	Protection Net	9371934013	9371934013	
32	Control Box	9371935010	9371935010		620	Inlet Pipe (Cond) Assy	—	9372185032	
34	Capacitor, Plastic	9900130022	9900130022		734	Top Panel	9371925011	9371925011	
37	Running Capacitor	9704436023	9704436023		754	Terminal Gasket Washer	9351053017	9351053017	
38	Capacitor Clamp Metal	9351770013	9351770013		772	Joint Pipe (Valve) -A	—	9372178010	
39	Propeller Fan Assy	9366378013	9366378013		815	Terminal-7P	9358660102	—	
41	Motor, Induct	9601671015	9601671015		815-3	Terminal-8P	—	9358660119	
45-1	Motor Bracket	9371929019	9371929019		821	Joint Pipe (Valve) -B	—	9372203033	
45-2	Motor Bracket-Top	9371931012	9371931012		823-2	Fuse Holder	0500063024	0500063024	
45-3	Motor Bracket-Ctr	9371930015	9371930015		824-4	Fuse	0600222529	0600222529	
45-4	Motor Bracket-Bottom	9371932019	9371932019		826	Condensing Pipe Assy	9371378046	—	
46	Compressor Assy	9368175009	9368175009		826	Condensing Pipe	—	9372194027	
47-1	Rubber (Discha. Pipe)	313194159807	—		827	Capillary Assy	9372197080	9372197103	
51	Special Nut M5	9300301015	9300301015		910	Strainer-B	—	9365099018	
55	Special Nut M8	9355091008	9355091008		989-1	Cord Clamp-A	9359822011	9359822011	
58	Suction Pipe-A	—	9372176078		989-2	Cord Clamp-B	9359823018	9359823018	
58-1	Suction Pipe-A	9372176061	—		990	Air Seal Plate	9372213018	9372213018	
64	Side Panel L, Ptd	9371927015	9371927015						

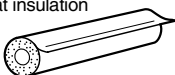
STANDARD ACCESSORIES

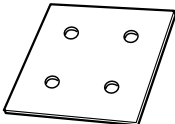
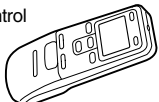
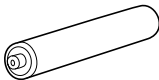
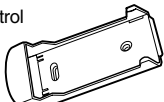

INDOOR UNIT ACCESSORIES

Name and Shape	Application	Part No.
Coupler heat insulation 	For indoor side pipe joint	9350716029
		9352766015
Special nut A (large flange) 	For installing indoor unit	313005446653
Special nut B (small flange) 	For installing indoor unit	313005446759
Template 	For ceiling hole cutting	9360256003
Remote control unit 	Use for air conditioner operation	9371190044 (Cooling model)
		9371190037 (Cooling & Heating model)
Battery (penlight) 	For remote control unit	0600185534
Remote control unit holder 	For mounting the remote control unit	9305642014
Tapping screw (φ 3 x 12) 	For remote control unit holder installation	301141533125

OUTDOOR UNIT ACCESSORIES

Name and Shape	Application	Part No.
Drain Pipe 	For outdoor unit drain piping work [Heat & Cool (Reverse cycle) model only]	9303029015

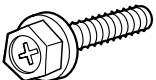
GRILLE ASSY ACCESSORIES

Name and Shape	Application	Part No.
Bolt 	For opening the refrigerant valve on the outdoor unit	0700139116
Washer 	For mounting grille	301801155020
Blower cover insulation 	For discharged air	9360047007



MANUFACTURER :

Fuji Denki Sosetsu Co., Ltd.

Tokyo, Japan